

DSBH120

CEILING HOUSING FOR DISCREET SURVEILLANCE

MAIN FEATURES

Directly fixed to the ceiling or false ceilings

Diameter 120mm (4.7in)

Available in transparent or smoked glass

Aluminium construction with bubble in acrylic

Adjustable camera mounting bracket

DESCRIPTION

Dustproof dome housing constructed from aluminium and lower bubble in acrylic. It allows the camera perfect camouflage, without compromise the quality of the video image.

The internal dimensions are suitable for CCD cameras. They don't need any bracket and can be directly attached to the ceiling or the false ceiling. Supplied with camera bracket and joint.

The installation is quick and allows easy access to the camera for maintenance or an eventual repositioning.



DSBH120

AVAILABLE MODELS

DSBH120	Smoked ceiling mount dome camera housing
DSBH120TR	Trasparent ceiling mount dome camera housing

TECHNICAL DATA

GENERAL

Upper part constructed from painted aluminium
 Lower bubble in acrylic, smoked or transparent

MECHANICAL

External dimensions (Ø): 185mm (7.3in)
 Bubble dimensions (Ø): 120mm
 Unit weight: 0.6kg (1.3lb)

ENVIRONMENT

Indoor

CERTIFICATIONS

CE EN61000-6-3, EN60065, EN50130-4

PACKAGE

Model Number	Weight	Dimensions (WxHxL)	Master carton
DSBH120	0.8kg (1.7lb)	14x25.5x20cm (5.5x10x7.9in)	15

TECHNICAL DRAWINGS

Sizes in millimeters.

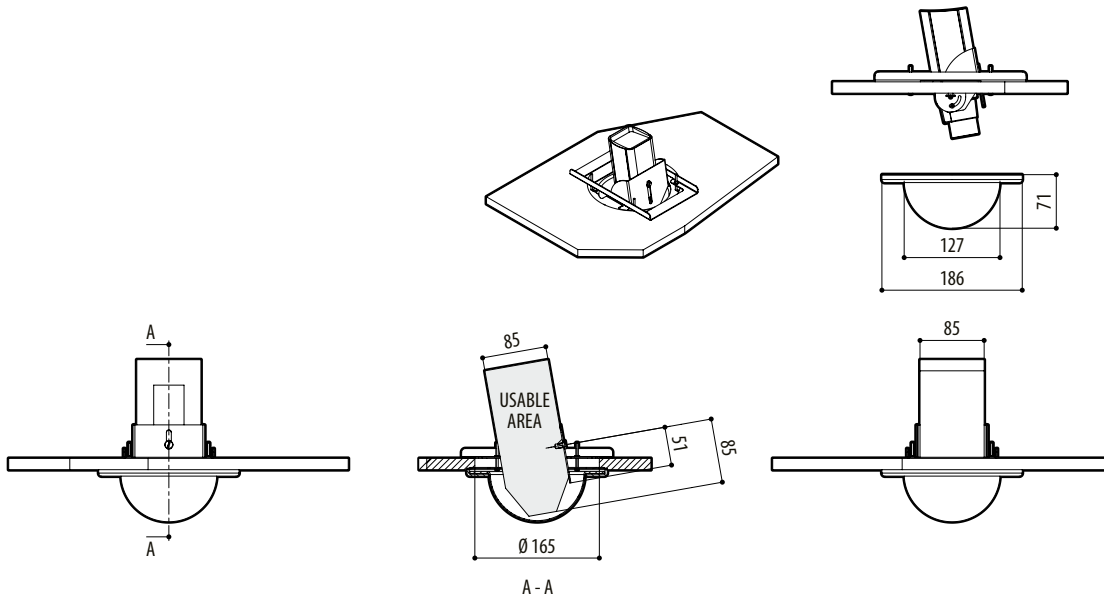

DSBH120