

# EU Declaration of Conformity

# SAMSUNG



***We hereby declare that the product***

Type of equipment : NETWORK CAMERA  
Brand Name / Trade Mark : SAMSUNG  
Model number : XND-8030RP  
Variant Model : -

***satisfies all the technical regulations applicable to the product within the scope of Council Directives 2014/30/EU***

EN 55022:2010 : Limits and methods of measurement of radio disturbance characteristics of information technology equipment  
EN 50581:2012 : Technical documentation for the assessment of electrical and electronic products with respect to the restriction of hazardous substances  
EN 50130-4:2011+A1:2014 : Product family standard: Immunity requirements for components of fire, intruder and social alarm systems  
EN 61000-4-2:2009 : Electrostatic discharge immunity test  
EN 61000-4-3:2006+A2:2010 : Radiated, radio-frequency, electromagnetic field immunity test  
EN 61000-4-4:2012 : Electrical fast transient/burst immunity test  
EN 61000-4-5:2014 : Surge immunity test  
EN 61000-4-6:2014 : Immunity to conducted disturbances, induced by radio-frequency fields

***All essential testing suites have been carried out.***

Manufacturer : Hanwha Techwin (Tianjin) Co., Ltd.  
Manufacturer address : No. 11 Weiliu Rd, Micro-Electronic Industrial Park, TEDA, Tianjin, 300385, People's Republic of China  
Telephone / Fax : 82-02-729-2900 / 82-02-729-2904 (www.hanwhatechwin.com)  
Applicant : Hanwha Techwin Co., Ltd.  
Applicant address : 1204, Changwon-daero, Seongsan-gu, Chang-won-si, Gyeongsangnam-do, Korea

***This declaration is issued under the sole responsibility of the manufacturer and his authorised representative.***

***Authorized signatory***

Name / Title : Jei Soon, Kang / Principal Research Engineer  
Date of issue : Jan. 23, 2017



# EMC TEST REPORT For CE

Test Report No. : KES-E1-17T0042  
Date of Issue : Jan, 23, 2017  
Product name : NETWORK CAMERA  
Model/Type No. : XND-8030RP  
Variant Model : -  
Applicant : Hanwha Techwin Co., Ltd.  
Applicant Address : 1204, Changwon-daero, Seongsan-gu, Changwon-si,  
Gyeongsangnam-do, Korea  
Manufacturer : Hanwha Techwin (Tianjin) Co.,Ltd.  
Manufacturer Address : No.11 Weiliu Rd, Micro-Electronic Industrial  
Park, TEDA, Tianjin, 300385, People's Republic of China  
Date of Receipt : Jan, 10, 2017  
Test date : Jan, 12, 2017 – Jan, 17, 2017  
Test Results :  **In Compliance**       **Not in Compliance**

Tested by

Jin Bae, Lee  
EMC Test Engineer

Reviewed by

Dong-Hun, Jang  
EMC Technical Manager



**KES Co., Ltd.**

C-3701, Simin-daero 365-40,  
Dongan-gu, Anyang-si, Gyeonggi-do, 14057, Korea  
Tel: +82-31-425-6200 / Fax: +82-31-424-0450  
www.kes.co.kr

Test report No.:  
KES-E1-17T0042  
Page (2) of (79)

---

## REPORT REVISION HISTORY

Date	Test Report No.	Revision History
Jan. 23, 2017	KES-E1-17T0042	Issued

***This report shall not be reproduced except in full, without the written approval of KES Co., Ltd. This document Jun be altered or revised by KES Co., Ltd. personnel only, and shall be noted in the revision section of the document. Any alteration of this document not carried out by KES Co., Ltd. will constitute fraud and shall nullify the document.***

---

This report shall not be reproduced except in full, without the written approval of KES Co., Ltd.  
The results shown in this test report refer only to the sample(s) tested unless otherwise stated.



---

## TABLE OF CONTENTS

1.0	General Product Description .....	4
1.1	Test Voltage & Frequency .....	6
1.2	Variant Model Differences.....	6
1.3	Device Modifications .....	6
1.4	Equipment Under Test.....	6
1.5	Support Equipments .....	6
1.6	External I/O Cabling .....	7
1.7	E.U.T Operating Mode(s) .....	8
1.8	Configuration.....	9
1.9	Calibration Details of Equipment Used for Measurement.....	10
1.10	Test Facility .....	10
1.11	Laboratory Accreditations and Listings .....	10
2.0	Test Regulations.....	11
2.1	Conducted Emissions at Mains Power Ports .....	13
2.2	Conducted Emissions at Telecommunication Ports .....	14
2.3	Radiated Electric Field Emissions(Below 1 GHz) .....	15
2.4	Radiated Electric Field Emissions(Above 1 GHz) .....	16
2.5	Harmonic Current Emissions .....	17
2.6	Voltage Fluctuations and Flicker .....	18
3.0	Criteria for compliance.....	19
3.1	Electrostatic Discharge.....	21
3.2	Radiated Electric Field Immunity .....	24
3.3	Electrical Fast Transients/Bursts .....	27
3.4	Surge Transients .....	29
3.5	Conducted Disturbance .....	33
3.6	Voltage Dips and Short Interruptions .....	37
	APPENDIX A – TEST DATA.....	39
	Conducted Emissions at Mains Power Ports.....	39
	Conducted Emissions at Telecommunication Ports .....	41
	Radiated Electric Field Emissions(Below 1 GHz) .....	44
	Radiated Electric Field Emissions(Above 1 GHz) .....	46
	Harmonic Current Emissions and Voltage Fluctuations and Flicker .....	54
	Test Setup Photos and Configuration .....	57
	Conducted Voltage Emissions .....	57
	Conducted Telecommunication Emissions .....	58
	Radiated Electric Field Emissions(Below 1 GHz) .....	60
	Radiated Electric Field Emissions(Above 1 GHz) .....	62
	Harmonic Current Emissions and Voltage Fluctuations and Flicker .....	64
	Electrostatic Discharge .....	65
	Radiated Electric Field Immunity .....	66
	Electrical Fast Transients/Bursts .....	67
	Surge Transients .....	69
	Conducted Disturbance .....	70
	Voltage Dips and Short Interruptions .....	72
	EUT External Photographs .....	73
	EUT Internal Photographs .....	74

---

This report shall not be reproduced except in full, without the written approval of KES Co., Ltd.  
The results shown in this test report refer only to the sample(s) tested unless otherwise stated.



## 1.0 General Product Description

### Main Specifications of E.U.T are:

XND-8030R	
<b>Video</b>	
Imaging Device	1/1.8" 6M CMOS
Total Pixels	3096(H) x 2094(V)
Effective Pixels	2616(H) x 1976(V)
Scanning System	Progressive Scan
Min. Illumination	Color : 0.2 lux(F1.6, 1/30sec) B/W : 0 Lux (IR LED On)
S / N Ratio	50dB
Video Out	CVBS : 1.0 Vp-p / 75Ω composite, 720x480(N), 720x576(P), for installation USB : Micro USB type B, 1280x720, for installation
<b>Lens</b>	
Focal Length (Zoom Ratio)	4.6mm Fixed
Max. Aperture Ratio	F1.6
Angular Field of View	H: 77.9°, V: 57.9°, D: 98.7°
Min. Object Distance	0.4m
Focus Control	Manual
Lens Type	Fixed
Mount Type	Board-in type
<b>Pan / Tilt / Rotate</b>	
Pan / Tilt / Rotate range	0° ~ 354° / 0° ~ 67° / 0° ~ 355°
<b>Operational</b>	
IR Viewable Length	30m(98.43ft)
Camera Title	Off / On (Displayed up to 85 characters) - WW : English/Numeric/Special Characters - China : English/Numeric/Special/Chinese Characters - Common : Multi-line (Max 5), Color (Grey/Green/Red/Blue/Black/White), Transparency, Auto Scale by Resolution
Day & Night	Auto (ICR) / Color / B/W / External / Schedule
Backlight Compensation	Off / BLC / HLC(Masking/Dimming), WDR
Wide Dynamic Range	120dB
Contrast Enhancement	SSDR (Off / On)
Digital Noise Reduction	SSNR5 (2D+3D Noise Filter) (Off / On)
Digital Image Stabilization	Off / On
Defog	Auto(input from fog detection) / Manual / Off
Motion Detection	Off/ On(8ea, 8point Polygonal zones), Handover
Privacy Masking	Off / On (32ea, polygonal zones) - Color : Grey/Green/Red/Blue/Black/White - Mosaic
Gain Control	Off / Low / Middle / High
White Balance	ATW / AWC / Manual / Indoor / Outdoor((included Mercury & Sodium)
Contrast	level adjustment
LDC	On/Off (5 levels with Min/Max)
Electronic Shutter Speed	Minimum / Maximum / Anti flicker (2 ~ 1/12,000sec)
Digital PTZ	24X, Digital PTZ(Preset, Group)
Flip / Mirror	Flip : On/Off Mirror : On/Off Hallway view : 90°/270°
Video & Audio Analytics	Tampering, Loitering, Directional Detection, Defocus Detection, Fog&Dust Detection, Virtual Line, Enter/Exit, Appear / Disappear, Audio Detection, Face Detection, Motion Detection, Digital Auto Tracking, Sound Classification, People counting, Heat map, Queue management
Alarm I/O	Input 1ea / Output 1ea
Remote Control Interface	-
RS-485 Protocol	-
Alarm Triggers	Alarm Input, Motion Detection, Video & Audio Analytics, Network Disconnect
Alarm events	File upload via FTP, E-Mail Notification via E-Mail local storage(SD/SDHC/SDXC) or NAS recording at Event Triggers External output DPTZ preset

This report shall not be reproduced except in full, without the written approval of KES Co., Ltd.  
The results shown in this test report refer only to the sample(s) tested unless otherwise stated.





## KES Co., Ltd.

C-3701, Simin-daero 365-40,  
Dongan-gu, Anyang-si, Gyeonggi-do, 14057, Korea  
Tel: +82-31-425-6200 / Fax: +82-31-424-0450  
www.kes.co.kr

Test report No.:  
KES-E1-17T0042  
Page (5) of (79)

Audio In	Selectable (Mic IN/Line IN), Built-in MIC. Max output level : 1Vrms Supply voltage: 2.5VDC(4mA), Input impedance: approx. 2K Ohm
Audio out	Line out. Max output level: 1 Vrms
Pixel Counter	Support
<b>Network</b>	
Ethernet	RJ-45 (10/100BASE-T)
Video Compression Form	H.265/H.264 (MPEG-4 Part 10/AVC) : Main/Baseline/High , Motion JPEG
Resolution	2560 x 1920, 2560 x 1440, 1920 x 1080, 1600 x 1200, 1280 x 1024, 1280 x 960 1280 x 720, 1024 x 768, 800 x 600, 800 x 448, 720 x 576, 720 x 480, 640 x 480, 640 x 360, 320 x
Max. Framerate	H.265/H.264 : Max. 30fps at all resolutions Motion JPEG : Max. 30fps
Smart Codec	Manual Mode (area-based : 5EA)
WiseStream II	Support
Video Quality Adjustment	H.264/H.265 : Target Bitrate Level Control MJPEG : Target Bitrate Level Control
Bitrate Control Method	H.264/H.265 : CBR or VBR MJPEG : VBR
Streaming Capability	Multiple Streaming (Up to 10 Profiles)
Audio Compression Form	G.711 u-law /G.726 Selectable G.726 (ADPCM) 8KHz, G.711 8KHz G.726 : 16Kbps, 24Kbps, 32Kbps, 40Kbps AAC-LC : 48Kbps at 8/16/32/48KHz
Audio Communication	Bi-directional (2-Way)
IP	IPv4, IPv6
Protocol	TCP/IP, UDP/IP, RTP(UDP), RTP(TCP), RTCP,RTSP, NTP, HTTP, HTTPS, SSL/TLS, DHCP, PPPoE, FTP, SMTP, ICMP, IGMP, SNMPv1/v2c/v3(MIB-2), ARP, DNS, DDNS, QoS, PIM-SM, UPnP, Bonjour
Security	HTTPS(SSL) Login Authentication Digest Login Authentication IP Address Filtering User access Log 802.1X Authentication (EAP-TLS, EAP-LEAP)
Streaming Method	Unicast / Multicast
Max. User Access	20 users at Unicast Mode
Edge Storage	SD/SDHC/SDXC 2slot (up to 512 GB) - Continuous recording(1'st slot to 2'nd slot) - Motion Images recorded in the SD/SDHC/SDXC memory card can be downloaded. . NAS(Network Attached Storage) Local PC for Instant Recording
Application Programming	ONVIF Profile S/G SUNAPI(HTTP API) Open Platform
Webpage Language	English, Korean, Chinese, French, Italian, Spanish, German, Japanese, Russian, Swedish, Portuguese, Czech, Polish, Turkish, Dutch, Hungarian, Greek
Web Viewer	Supported OS: Windows 7, 8.1, 10, Mac OS X 10.10, 10.11, 10.12 <b>Non-plugin Webviewer</b> Supported Browser: Google Chrome 54, MS Edge 38, Mozilla Firefox 49(Window 64bit only) , Apple Safari 9 (Mac OS X only) <b>Plug-in Webviewer</b> Supported Browser : MS Explore 11, Apple Safari 9 (Mac OS X only)
Central Management Soft	SmartViewer, SSM
<b>Environmental</b>	
Operating Temperature / Humidity	-10°C ~ +55°C (-14°F ~ +131°F) / Less than 90% RH
Storage Temperature / Humidity	-50°C ~ +60°C (-22°F ~ +140°F) / Less than 90% RH
Ingress Protection	-
Vandal Resistance	IK08
<b>Electrical</b>	
Input Voltage / Current	DC12V,PoE(IEEE802.3af,Class3)
Power Consumption	Max. 8W(12VDC), Max. 9W(PoE)
<b>Mechanical</b>	

This report shall not be reproduced except in full, without the written approval of KES Co., Ltd.  
The results shown in this test report refer only to the sample(s) tested unless otherwise stated.



## 1.1 Test Voltage & Frequency

Unless indicated otherwise on the individual data sheet or test results, the test voltage and frequency was as indicated below.

Voltage       220 Vac    230 Vac    24 Vac    12 Vdc    PoE  
Frequency     50 Hz     60 Hz            Hz

## 1.2 Variant Model Differences

Not applicable

## 1.3 Device Modifications

Not applicable

## 1.4 Equipment Under Test

Description	Model Number	Serial Number	Manufacturer	Remarks
NETWORK CAMERA	XND-8030RP	-	Hanwha Techwin(Tianjin) Co.,Ltd.	E.U.T

## 1.5 Support Equipments

Description	Model Number	Serial Number	Manufacturer	Remarks
POE Adapter	KPL-060F	-	CHANNEL WELL TECHNOLOGY	-
Notebook	X56K	HN11N5151FJ0045W	HANSUNG	-
Notebook Adapter	A12-120P1A	F180271552011758	CHICONY POWER TECHNOLOGY CO.,LTD.	-
Phone	A1530	-	APPLE	-
MIC	CMK-303	-	CAMAC	-
Speaker	BR10000A CUVE	-	BEIJING EDIFIER HI-TECH GROUP.	-
Alarm	-	-	-	-
SD card	-	-	SanDisk	-

This report shall not be reproduced except in full, without the written approval of KES Co., Ltd.  
The results shown in this test report refer only to the sample(s) tested unless otherwise stated.

## 1.6 External I/O Cabling

- DC 12 V Mode

Start		END		Cable Spec.	
Description	I/O Port	Description	I/O Port	Length	Shield
NETWORK CAMERA ( E.U.T )	RJ-45	Notebook	RJ-45	3.0	U
	7 Pin	MIC	3.5 mm	1.7	U
		Speaker	3.5 mm	1.6	U
		Alarm	2 pin	3.0	U
	Slot	SD card	Slot	-	-
Notebook	Audio in	Phone	Audio out	1.7	U

- POE Mode

Start		END		Cable Spec.	
Description	I/O Port	Description	I/O Port	Length	Shield
NETWORK CAMERA ( E.U.T )	RJ-45 (POE)	POE Adapter	RJ-45 (POE)	3.0	U
	7 Pin	MIC	3.5 mm	1.7	U
		Speaker	3.5 mm	1.6	U
		Alarm	2 pin	3.0	U
	Slot	SD card	Slot	-	-
Notebook	Audio in	Phone	Audio out	1.7	U
	RJ-45 (DATA)	POE Adapter	RJ-45 (DATA)	3.0	U

\* Unshielded=U, Shielded=S





## 1.7 E.U.T Operating Mode(s)

Test mode	operating
DC 12 V , POE	E.U.T Monitoring, 1 kHz, Ping Test

E.U.T Test operating S/W		
Name	Version	Manufacture Company
SmartViewer	-	Hanwha Techwin Co., Ltd.

This report shall not be reproduced except in full, without the written approval of KES Co., Ltd.  
The results shown in this test report refer only to the sample(s) tested unless otherwise stated.

## 1.8 Configuration

■ AC Main  
 □ DC Main

- DC 12 V Mode

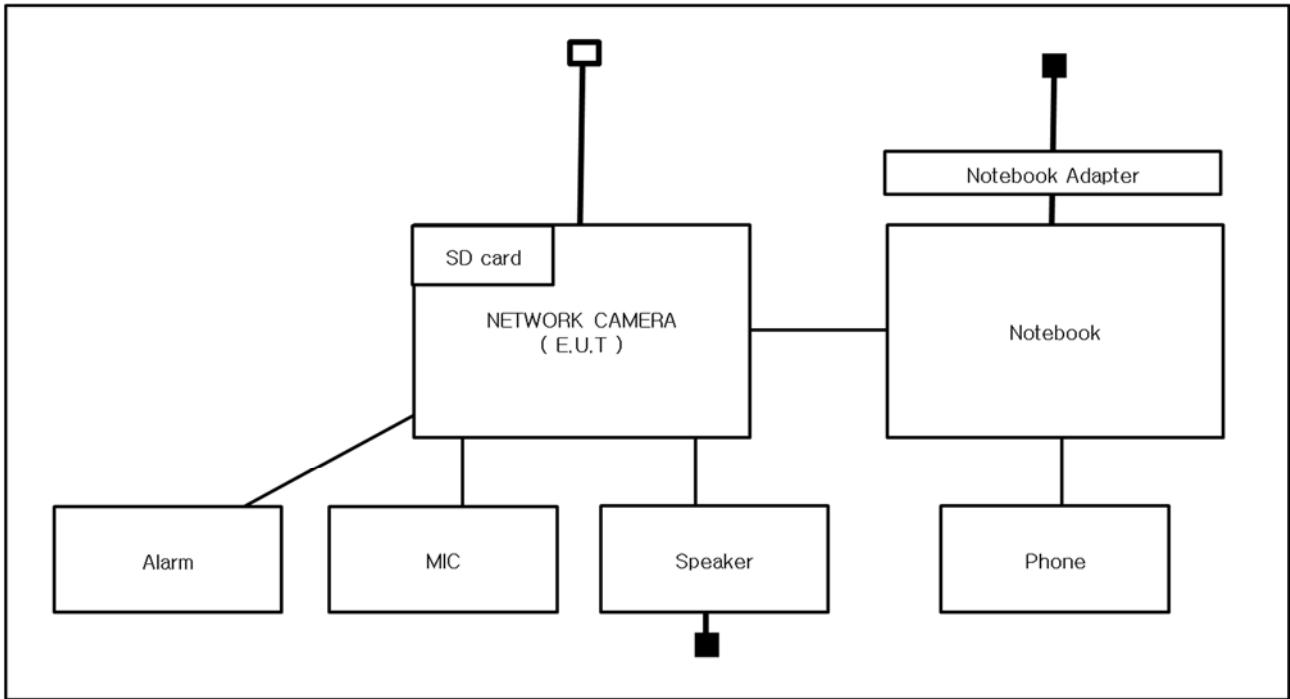

- POE Mode

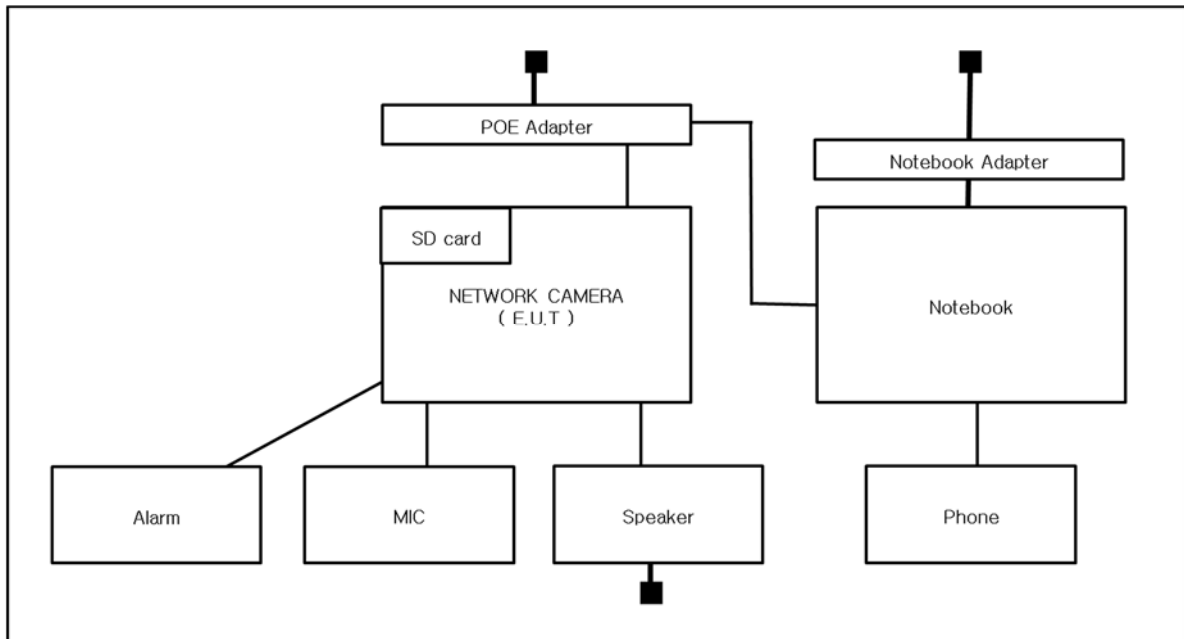

This report shall not be reproduced except in full, without the written approval of KES Co., Ltd.  
 The results shown in this test report refer only to the sample(s) tested unless otherwise stated.







## 1.9 Calibration Details of Equipment Used for Measurement

Test equipment and test accessories are calibrated on regular basis. The maximum time between calibrations is one year or what is recommended by the manufacturer, whichever is less.

## 1.10 Test Facility

The measurement facility is located at 473-21 Gayeo-ro, Yeosu-si, Gyeonggi-do, 12658, Korea. The sites are constructed in conformance with the requirements of ANSI C63.4 and CISPR Publication 22.

## 1.11 Laboratory Accreditations and Listings

Country	Agency	Scope of Accreditation	Logo
USA	FCC	3 & 10 meter Open Area Test Sites and one conducted site to perform FCC Part 15/18 measurements.	
JAPAN	VCCI	Mains Ports Conducted Interference Measurement, Telecommunication Ports Conducted Disturbance Measurement and Radiation 10 meter site, Facility for measuring radiated disturbance above 1 GHz	 R-4308, C-4798, T-2311, G-914
KOREA	MSIP	EMI (10 meter Open Area Test Site and two conducted sites) Radio(3 & 10 meter Open Area Test Sites and one conducted site) EMS (ESD, RS, EFT/Burst, Surge, CS, Magnetic, Dips and interruptions)	 KR0100
Canada	IC	3 & 10 meter Open Area Test Sites and one conducted site	 4769B-1
Europe	CE	EMI (10 meter Open Area Test Site and two conducted sites) Radio(3 & 10 meter Open Area Test Sites and one conducted site) EMS (ESD, RS, EFT/Burst, Surge, CS, Magnetic, Dips and interruptions)	
International	KOLAS	EMI (10 meter Open Area Test Site and two conducted sites) Radio(3 & 10 meter Open Area Test Sites and one conducted site) EMS (ESD, RS, EFT/Burst, Surge, CS, Magnetic, Dips and interruptions)	

## 2.0 Test Regulations

The emissions tests were performed according to following regulations:

**EMC – Directive 2014/30/EU**

EN 61000-6-3:2011

EN 61000-6-1:2007

EN 61000-6-4:2007 +A1:2011

EN 61000-6-2:2005

EN 55011:2007 +A1:2010

Group 1  
 Class A

Group 2  
 Class B

EN 55014-1:2006 +A2:2011

EN 55014-2:1997 +A2:2008

EN 55015:2013

EN 61547:2009

EN 55022:2010

Class A

Class B

EN 55024:2010 +A1:2015

EN 50130-4:2011 +A1:2014

EN 61000-3-2:2014

EN 61000-3-3:2013

EN 61326-1:2013



- 
- |   |                                  |                                  |
|---|----------------------------------|----------------------------------|
| <input type="checkbox"/> <b>VCCI V-3 / 2015.04</b>            | <input type="checkbox"/> Class A | <input type="checkbox"/> Class B |
| <input type="checkbox"/> <b>AS/NZS CISPR22:2009 +A1:2010</b>  | <input type="checkbox"/> Class A | <input type="checkbox"/> Class B |
| <input type="checkbox"/> <b>47 CFR Part 15, Subpart B</b>     |                                  |                                  |
| <input type="checkbox"/> CISPR 22:2009 +A1:2010               | <input type="checkbox"/> Class A | <input type="checkbox"/> Class B |
| <input type="checkbox"/> ANSI C63.4-2009                      |                                  |                                  |
| <input type="checkbox"/> <b>IC Regulation ICES-003 : 2016</b> |                                  |                                  |
| <input type="checkbox"/> CAN/CSA CISPR 22-10                  | <input type="checkbox"/> Class A | <input type="checkbox"/> Class B |
| <input type="checkbox"/> ANSI C63.4-2014                      |                                  |                                  |
| <input type="checkbox"/> <b>RE- Directive 2014/53/EU</b>      |                                  |                                  |
| <input type="checkbox"/> EN 301 489-1 V1.9.2                  |                                  |                                  |
| <input type="checkbox"/> Equipment for fixed use              |                                  |                                  |
| <input type="checkbox"/> Equipment for vehicular use          |                                  |                                  |
| <input type="checkbox"/> Equipment for portable use           |                                  |                                  |
| <input type="checkbox"/> EN 301 489-3 V1.6.1                  |                                  |                                  |
| <input type="checkbox"/> EN 301 489-17 V2.2.1                 |                                  |                                  |
| <input type="checkbox"/> EN 60945:2002                        |                                  |                                  |

---

This report shall not be reproduced except in full, without the written approval of KES Co., Ltd.  
The results shown in this test report refer only to the sample(s) tested unless otherwise stated.

## 2.1 Conducted Emissions at Mains Power Ports

**Test Date**

N/A

**Test Location**

Electro wave Shieldroom

**Test Equipment**

Used	Description	Model Number	Manufacturer	Serial Number	Cal. Due
<input type="checkbox"/>	EMI Test Receiver	ESR3	R & S	101783	05, 03, 2017
<input type="checkbox"/>	LISN	ENV216	R & S	101137	02, 04, 2017
<input type="checkbox"/>	LISN	ENV216	R & S	101786	05, 02, 2017
<input type="checkbox"/>	Electro wave Shieldroom	-	SEMITEC	-	-
<input type="checkbox"/>	EMI Test S/W	EMC32	R&S	9.12.00	-

**Test Conditions**Temperature: °C  
Relative Humidity: %**Frequency Range of Measurement**

150 kHz to 30 MHz

**Instrument Settings**

IF Band Width: 9 kHz

**Test Results**

The requirements are:

- PASS  
 NOT PASS  
 NOT APPLICABLE

**Remarks**N/A Because the E.U.T power is 12 v (dc) power and PoE, limits are not specified.



## 2.2 Conducted Emissions at Telecommunication Ports

### Test Date

Jan, 12, 2017

### Test Location

Electro wave Shieldroom

### Test Equipment

Used	Description	Model Number	Manufacturer	Serial Number	Cal. Due
<input checked="" type="checkbox"/>	EMI Test Receiver	ESR3	R & S	101783	05,03,2017
<input checked="" type="checkbox"/>	LISN	ENV216	R & S	101137	02,04,2017
<input checked="" type="checkbox"/>	LISN	ENV216	R & S	101786	05,02,2017
<input checked="" type="checkbox"/>	8-Wire ISN CAT3	CAT3 8158	Schwarzbeck Mess	8158-0019	04,01,2017
<input checked="" type="checkbox"/>	8-Wire ISN CAT5	CAT5 8158	Schwarzbeck Mess	8158-0030	04,01,2017
<input checked="" type="checkbox"/>	PULSE LIMITER	ESH3-Z2	R&S	101914	12,13,2017
<input checked="" type="checkbox"/>	Shield Room #3	-	SEMITEC	-	-
<input checked="" type="checkbox"/>	EMI Test S/W	EMC32	R & S	9.12.00	-

### Test Conditions

Temperature: 21,2 °C  
Relative Humidity: 42,0 %

### Frequency Range of Measurement

150 kHz to 30 MHz

### Instrument Settings

IF Band Width: 9 kHz

### Test Results

The requirements are:

- PASS
- NOT PASS
- NOT APPLICABLE

### Remarks

See Appendix A for test data.

## 2.3 Radiated Electric Field Emissions(Below 1 GHz)

### Test Date

Jan, 13, 2017

### Test Location

Open Area Test Site #1       Open Area Test Site #2

### Test Equipment

Used	Description	Model Number	Manufacturer	Serial Number	Cal. Due
<input checked="" type="checkbox"/>	EMI TEST Receiver	ESR3	R&S	101781	05, 03, 2017
<input checked="" type="checkbox"/>	Trilog-Broadband ANT	VULB 9163	Schwarzbeck	714	11, 28, 2018
<input checked="" type="checkbox"/>	Open Area Test Site	-	KES	-	-
<input checked="" type="checkbox"/>	Antenna Mast	-	DAEIL EMC	-	-
<input checked="" type="checkbox"/>	Turn Table	-	DAEIL EMC	-	-
<input checked="" type="checkbox"/>	EMI Test S/W	-	-	-	-

### Test Conditions

Temperature: 0,3 °C  
Relative Humidity: 81,0 %

### Frequency Range of Measurement

30 MHz to 1 GHz

### Instrument Settings

IF Band Width: 120 kHz

### Test Results

The requirements are:

- PASS  
 NOT PASS  
 NOT APPLICABLE

### Remarks

See Appendix A for test data.

## 2.4 Radiated Electric Field Emissions(Above 1 GHz)

### Test Date

Jan, 13, 2017

### Test Location

Semi Anechoic Chamber #2

### Test Equipment

Used	Description	Model Number	Manufacturer	Serial Number	Cal. Due
<input checked="" type="checkbox"/>	DOUBLE RIDGED HORN ANTENNA	SAS-571	A.H.SYSTEM,INC	781	05, 07, 2017
<input checked="" type="checkbox"/>	EMI Test Receiver	ESU26	R&S	100552	04, 24, 2017
<input checked="" type="checkbox"/>	Broadband Coaxial Preamplifier	BBV 9718	Schwarzbeck Mess - Elektronik	9718-246	10, 14, 2017
<input checked="" type="checkbox"/>	Semi Anechoic Chamber #2	-	SEMITEC	-	-
<input checked="" type="checkbox"/>	Antenna Mast	-	AUDIX	-	-
<input checked="" type="checkbox"/>	Turn Table	-	AUDIX	-	-
<input checked="" type="checkbox"/>	EMI Test S/W	e3	AUDIX	8.083b	-

### Test Conditions

Temperature: 21,4 °C  
Relative Humidity: 40,4 %

### Frequency Range of Measurement

1 GHz to 6 GHz

### Instrument Settings

IF Band Width: 1 MHz

### Test Results

The requirements are:

- PASS
- NOT PASS
- NOT APPLICABLE

### Remarks

See Appendix A for test data.

## 2.5 Harmonic Current Emissions

**Test Date**

N/A

**Test Location**

Electro wave Shieldroom

**Test Equipment**

Used	Description	Model Number	Manufacturer	Serial Number	Cal. Due
<input type="checkbox"/>	AC Source	ACS 500 N	EM TEST	V1024106760	08, 08, 2017
<input type="checkbox"/>	Digital Power Analyzer	DPA 500 N	EM TEST	V1024106759	08, 08, 2017
<input type="checkbox"/>	EMI Test S/W	dpa.control	EM TEST AG	5.4.8.0	-

**Test Conditions**

Temperature: °C

Relative Humidity: %

**Classification of Equipment for Harmonic Current Emissions**

- Class A
- Class B
- Class C(Below 25 W)
- Class C(Above 25 W)
- Class D

**Test Results**

The requirements are:

- PASS
- NOT PASS
- NOT APPLICABLE

**Remarks**N/A Because the E.U.T power is less than 75 W, limits are not specified.



## 2.6 Voltage Fluctuations and Flicker

### Test Date

N/A

### Test Location

Electro wave Shieldroom

### Test Equipment

Used	Description	Model Number	Manufacturer	Serial Number	Cal. Due
<input type="checkbox"/>	AC Source	ACS 500 N	EM test	V1024106760	08, 08, 2017
<input type="checkbox"/>	Digital Power Analyzer	DPA 500 N	EM test	V1024106759	08, 08, 2017
<input type="checkbox"/>	EMI Test S/W	dpa.control	EM TEST AG	5.4.8.0	-

### Test Conditions

Temperature: °C

Relative Humidity: %

### Test Results

The requirements are:

- PASS
- NOT PASS
- NOT APPLICABLE

### Remarks

N/A Because the E.U.T power is 12 v (dc) power and PoE, limits are not specified.

### 3.0 Criteria for compliance

Criteria for compliance was based on the following guidelines:  
EN 50130-4:2011 +A1:2014 Alarm systems-Part 4: Electromagnetic compatibility Product family standard: Immunity requirements for components of fire, intruder and social alarm systems

The variety and the diversity of the apparatus within the scope of this document makes it difficult to define precise criteria for the evaluation of the immunity test results.

If as a result of the application of the tests defined in this standard, the apparatus becomes dangerous or unsafe then the apparatus shall be deemed to have failed the test.

A functional description and a definition of performance by the manufacture and noted in the test report, based on the following criteria:

#### Electrostatic discharge

There shall be no damage, malfunction or change of status due to the conditioning.

Flickering of an indicator during the application of discharge is permissible, providing that is no residual change in the EUT or any change in outputs, which could be interpreted by associated equipment as a change.

#### Radiated electromagnetic fields

There shall be no damage, malfunction or change of status due to the conditioning.

Flickering of an indicator during the application of discharge is permissible, providing which could be interpreted by associated equipment as a change, and no such

Flickering of indicators occurs at a field strength of 3 V/m.

For components of CCTV systems, where the picture is allowed at 10 V/m, providing.

(a) there is no permanent damage or change to EUT

(e.g. no corruption of memory or changes to programmable setting etc.)

(b) at 3 V/m, any deterioration of the picture is so minor that the system could still be used; and

(c) there is no observable deterioration of the picture at 1 V/m.



---

**Fast transient burst / slow high energy voltage surge**

There shall be no damage, malfunction or change of status due to the conditioning.

Flickering of an indicator during the application of discharge is permissible, providing

That there is no residual is permissible, providing that there is no residual change in the EUT or any change in outputs, which could be interpreted by associated equipment as a change.

**Conducted RF immunity**

There shall be no damage, malfunction or change of status due to the conditioning.

Flickering of an indicator during the application of discharge is permissible, providing

That there is no residual is permissible, providing that there is no residual change in the EUT or any change in outputs, which could be interpreted by associated equipment as a change, and no such flickering of indicators oeuvres at  $U = 130 \text{ dB}\mu\text{V}$ .

For component of CCTV systems, where the status is monitored by observing the TV picture, then deterioration of the picture is allowed at  $U = 140 \text{ dB}\mu\text{V}$ , providing:

(a) there is no permanent damage or change to the EUT

(e.g. no corruption of memory or changes to programmable settings etc.)

(b) at  $U = 130 \text{ dB}\mu\text{V}$ , any deterioration of the picture is so minor that the system could still be used; and

(c) there in no observable deterioration of the picture at  $U = 120 \text{ dB}\mu\text{V}$ .

**Voltage dip/interruption / Voltage variation**

There shall be no damage, malfunction or change of status due to the conditioning.

Flickering of an indicator during the conditioning is permissible, providing that there is no residual

change in the EUT or any change in outputs, which could be interpreted by associated equipment

as a change. The EUT shall meet the acceptance criteria for the functional test, after the conditioning.

### 3.1 Electrostatic Discharge

**Reference Standard**

EN 61000-4-2:2009

**Test Date**

Jan, 16, 2017

**Test Location**

EMS-ESD: Electro wave Shieldroom

**Test Equipment**

Used	Description	Model Number	Manufacturer	Serial Number	Cal. Due
<input checked="" type="checkbox"/>	ESD SIMULATOR	ESS-2000	Noise Ken	ESS05X4620	02, 24, 2017
<input checked="" type="checkbox"/>	HCP	-	Noise Ken	-	-
<input checked="" type="checkbox"/>	VCP	-	Noise Ken	-	-
<input checked="" type="checkbox"/>	EMS Test S/W	-	-	-	-

**Test Conditions**

Temperature: 24,1 °C  
Relative Humidity: 40,2 %  
Atmospheric Pressure: 100,2 kPa

**Test Specifications**

Discharge Factor: ≥ 1 s

Discharge Impedance: 330 ohm / 150 pF

Kind of Discharge: Air, Contact (direct and indirect)

Polarity: Positive and Negative

Number of Discharge: 10 at all locations for Air discharge  
10 at all locations for Contact discharge

Discharge Voltage:	<b>Contact</b>	<b>Air</b>	<b>HCP</b>	<b>VCP</b>
	<input type="checkbox"/> 2 kV	<input checked="" type="checkbox"/> 2 kV	<input type="checkbox"/> 2 kV	<input type="checkbox"/> 2 kV
	<input type="checkbox"/> 4 kV	<input checked="" type="checkbox"/> 4 kV	<input type="checkbox"/> 4 kV	<input type="checkbox"/> 4 kV
	<input checked="" type="checkbox"/> 6 kV	<input type="checkbox"/> 6 kV	<input checked="" type="checkbox"/> 6 kV	<input checked="" type="checkbox"/> 6 kV
	<input type="checkbox"/> 8 kV	<input checked="" type="checkbox"/> 8 kV	<input type="checkbox"/> 8 kV	<input type="checkbox"/> 8 kV
	<input type="checkbox"/> 15 kV	<input type="checkbox"/> 15 kV	<input type="checkbox"/> 15 kV	<input type="checkbox"/> 15 kV

Notes: HCP: Horizontal coupling plane  
VCP: Vertical coupling plane

Required Performance Criteria:  Complied

This report shall not be reproduced except in full, without the written approval of KES Co., Ltd.  
The results shown in this test report refer only to the sample(s) tested unless otherwise stated.

**Location of Discharge:**

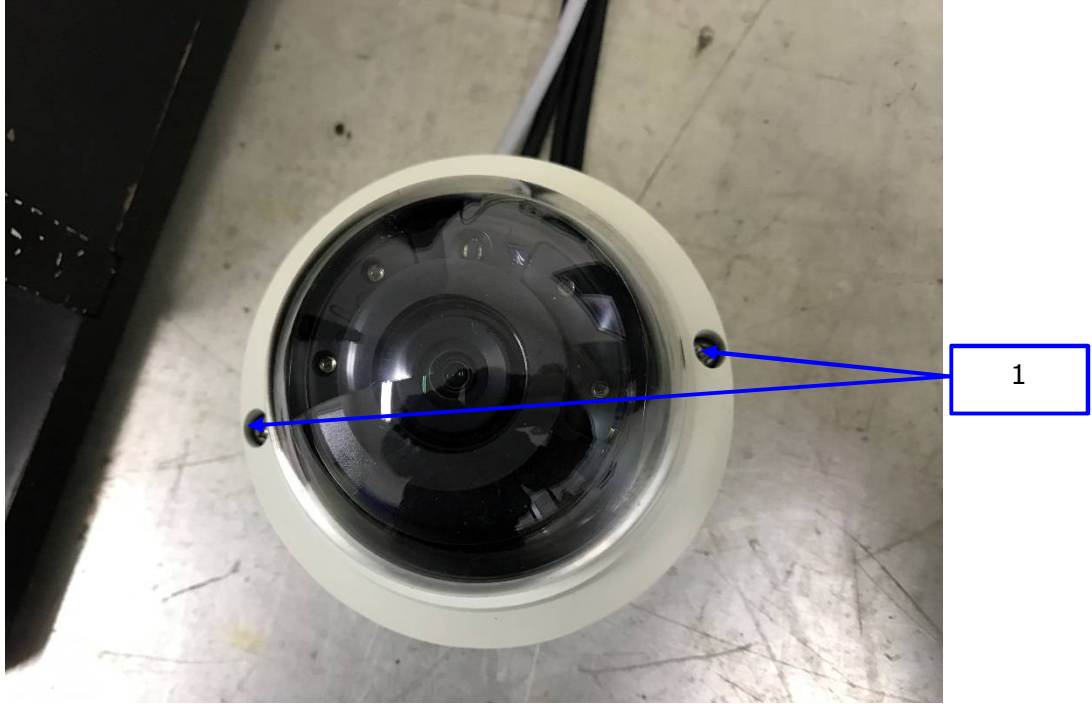
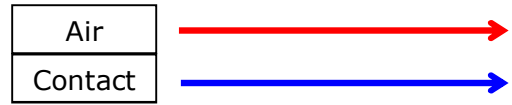

This report shall not be reproduced except in full, without the written approval of KES Co., Ltd.  
The results shown in this test report refer only to the sample(s) tested unless otherwise stated.



**Test Data**

- DC 12 V Mode

Indirect Discharge

No.	Test Point	Discharge Method	Observations	Remarks
1	HCP Contact	Contact Discharge	Complied	-
2	VCP Contact	Contact Discharge	Complied	-

Direct Discharge

No.	Test Point	Discharge Method	Observations	Remarks
1	Screw	Contact Discharge	Complied	-

- POE Mode

Indirect Discharge

No.	Test Point	Discharge Method	Observations	Remarks
1	HCP Contact	Contact Discharge	Complied	-
2	VCP Contact	Contact Discharge	Complied	-

Direct Discharge

No.	Test Point	Discharge Method	Observations	Remarks
1	Screw	Contact Discharge	Complied	-

Note: "Blank" = Not performed

Observations:  
Complied – No degradation of function

**Test Results**

- PASS Required Performance Criteria
- NOT PASS Required Performance Criteria

**Remarks**

PASS Required Performance Criteria.

## 3.2 Radiated Electric Field Immunity

### Reference Standard

EN 61000-4-3:2006 +A2:2010

### Test Date

Jan, 14, 2017

### Test Location

EMS-RS:  Semi Anechoic Chamber #1       Semi Anechoic Chamber #2

### Test Equipment

Used	Description	Model Number	Manufacturer	Serial Number	Cal. Due
<input checked="" type="checkbox"/>	Signal Generator	ESG-3000A	HP	US37040210	11, 01, 2017
<input checked="" type="checkbox"/>	Amplifier	ITA0300-200	Infinitech	-	11, 01, 2017
<input checked="" type="checkbox"/>	Amplifier	ITA0750-200	Infinitech	-	11, 01, 2017
<input checked="" type="checkbox"/>	Amplifier	ITA1500-100	Infinitech	-	11, 01, 2017
<input checked="" type="checkbox"/>	Amplifier	ITA2500-100	Infinitech	-	11, 01, 2017
<input checked="" type="checkbox"/>	GPIB INTERFACE CONTROL	SYSTEM CONTROL UNIT	Infinitech	-	-
<input checked="" type="checkbox"/>	POWER SUPPLY	SYSTEM POWER SUPPLY	Infinitech	-	-
<input checked="" type="checkbox"/>	Power Meter	E4419B	Agilent	MY45101506	06, 27, 2017
<input checked="" type="checkbox"/>	Average Power Sensor	E9301A	Agilent	-	06, 27, 2017
<input checked="" type="checkbox"/>	Average Power Sensor	E9301A	Agilent	MY41495698	11, 17, 2017
<input checked="" type="checkbox"/>	Stacked Double Log-Per-Antenna	STPL9128 D	SCHWARZBECK	9128D038	-
<input checked="" type="checkbox"/>	Semi Anechoic Chamber #2	-	SEMITEC	-	-
<input checked="" type="checkbox"/>	EMS Test S/W	KTI_RS2012	KOREA TECHNOLOGY INSTITUTE CO., LTD	2.1.1	-

This report shall not be reproduced except in full, without the written approval of KES Co., Ltd.  
The results shown in this test report refer only to the sample(s) tested unless otherwise stated.



## Test Conditions

Temperature: 22,0 °C  
Relative Humidity: 39,8 %  
Atmospheric Pressure: 100,5 kPa

## Test Specifications

Antenna Polarization: Horizontal & vertical unless indicated otherwise

Antenna Distance:  3 m

Field Strength:  1 V/m  3 V/m  
 10 V/m

Frequency Range:  80 MHz to 1 GHz  1,4 GHz to 2,7 GHz  
 80 MHz to 2,7 GHz

Modulation:  AM, 80 %, 1 kHz sine wave  
 PM, 1 Hz (0,5 s ON : 0,5 s OFF)

Frequency step:  1 % step

Dwell Time:  1 s  3 s

# of Sides Radiated:  4

Required Performance Criteria:  Complied





**Test Data**

- DC 12 V Mode

Side Exposed	Observations	
	Horizontal	Vertical
Front	Complied	Complied
Right	Complied	Complied
Back	Complied	Complied
Left	Complied	Complied

- PoE Mode

Side Exposed	Observations	
	Horizontal	Vertical
Front	Complied	Complied
Right	Complied	Complied
Back	Complied	Complied
Left	Complied	Complied

Note: "Blank" = Not performed

Observations:  
Complied – No degradation of function

**Test Results**

- PASS Required Performance Criteria
- NOT PASS Required Performance Criteria

**Remarks**

PASS Required Performance Criteria.

This report shall not be reproduced except in full, without the written approval of KES Co., Ltd.  
The results shown in this test report refer only to the sample(s) tested unless otherwise stated.

### 3.3 Electrical Fast Transients/Bursts

**Reference Standard**

EN 61000-4-4:2012

**Test Date**

Jan, 17, 2017

**Test Location**

EMS-EFT: Electro wave Shieldroom

**Test Equipment**

Used	Description	Model Number	Manufacturer	Serial Number	Cal. Due
<input checked="" type="checkbox"/>	ULTRA COMPACT SIMULATOR	UCS 500 N5	EM TEST	V0936105120	06, 27, 2017
<input checked="" type="checkbox"/>	MOTOR VARIAC	MV2616	EM TEST	V0936105123	06, 27, 2017
<input checked="" type="checkbox"/>	CAPACITIVE COUPLING CLAMP	HFK	EM TEST	070925	06, 27, 2017
<input checked="" type="checkbox"/>	EMS Test S/W	iec.control	EM TEST	5.0.9.0	-

**Test Conditions**

Temperature: 23,3 °C  
Relative Humidity: 38.1 %  
Atmospheric Pressure: 99,8 kPa

**Test Specifications**

Pulse Amplitude & Polarity:  
(DC Power Lines)  ± 1.0 kV  ± 2.0 kV  
 ± 4.0 kV

Pulse Amplitude & Polarity:  
(Other supply / Signal Lines)  ± 0.5 kV  ± 1.0 kV  
 ± 2.0 kV

Burst Period:  300 ms  2 s

Repetition Rate:  5 kHz  100 kHz

Duration of Test Voltage:  ≥ 1 min

Required Performance Criteria:  Complied

This report shall not be reproduced except in full, without the written approval of KES Co., Ltd.  
The results shown in this test report refer only to the sample(s) tested unless otherwise stated.

**Test Data**

- DC 12 V Mode

Input a.c. power ports – Coupling/Decoupling Network used

Mode of Application	Observations	
	(+) Burst (kV)	(-) Burst (kV)
-	-	-

Input d.c. power ports – Coupling/Decoupling Network used

Mode of Application	Observations	
	(+) Burst (kV)	(-) Burst (kV)
L1 – L2	Complied	Complied

Signal ports and telecommunication ports – Coupling Clamp used

Mode of Application	Observations	
	(+) Burst (kV)	(-) Burst (kV)
RJ-45	Complied	Complied
Alarm	Complied	Complied

- PoE Mode

Input a.c. power ports – Coupling/Decoupling Network used

Mode of Application	Observations	
	(+) Burst (kV)	(-) Burst (kV)
-	-	-

Input d.c. power ports – Coupling/Decoupling Network used

Mode of Application	Observations	
	(+) Burst (kV)	(-) Burst (kV)
-	-	-

Signal ports and telecommunication ports – Coupling Clamp used

Mode of Application	Observations	
	(+) Burst (kV)	(-) Burst (kV)
RJ-45(POE)	Complied	Complied
Alarm	Complied	Complied

Note: “Blank” = Not performed

Observations:  
Complied – No degradation of function

**Test Results**

- PASS Required Performance Criteria
- NOT PASS Required Performance Criteria

**Remarks**

PASS Required Performance Criteria.

This report shall not be reproduced except in full, without the written approval of KES Co., Ltd.  
The results shown in this test report refer only to the sample(s) tested unless otherwise stated.

### 3.4 Surge Transients

**Reference Standard**

EN 61000-4-5:2014

**Test Date**

Jan, 17, 2017

**Test Location**

EMS-Surge: Electro wave Shieldroom

**Test Equipment**

Used	Description	Model Number	Manufacturer	Serial Number	Cal. Due
<input checked="" type="checkbox"/>	ULTRA COMPACT SIMULATOR	UCS 500 N5	EM TEST	V0936105120	06, 27, 2017
<input checked="" type="checkbox"/>	MOTOR VARIAC	MV2616	EM TEST	V0936105123	06, 27, 2017
<input checked="" type="checkbox"/>	CDN	CNV 508N1	EM TEST	P1551168979	04, 27, 2017
<input type="checkbox"/>	CDN	CNV 508T5	EM TEST	P1549168422	04, 27, 2017
<input checked="" type="checkbox"/>	EMS Test S/W	iec.control	EM TEST	5.0.9.0	-

**Test Conditions**Temperature: 23,3 °C  
Relative Humidity: 38,1 %  
Atmospheric Pressure: 99,8 kPa



---

## Test Specifications

### AC Power Lines

Source Impedance: 12 ohm for common mode and 2 ohm for differential mode

Surge Amplitude : Common Mode  
 (0,5 / 1,0 / 2,0) kV  
Differential Mode  
 (0,5 / 1,0) kV

Number of Surges:  5 surges per angle

Angle:  0°, 90°, 180°, 270° (input a.c. power port)

Polarity:  Positive & Negative

Repetition Rate:  1 surge per min  1 surge per 30 sec.

Required Performance Criteria:  Complied

### Other supply / Signal Lines

Source Impedance: 42 ohm for common mode

Surge Amplitude: Common Mode  
 (0,5 / 1,0) kV

Number of Surges:  5 Surges

Polarity:  Positive & Negative

Repetition Rate:  1 surge per min  1 surge per 30 sec.

Required Performance Criteria:  Complied

**Test Data**

- DC 12 V Mode

Line to Line – Differential Mode

Mode of Application	Observations	
	(+) Surge (kV)	(-) Surge (kV)
L – N	-	-
L – PE	-	-
N – PE	-	-

Line to Earth – Common Mode

Mode of Application	Observations	
	(+) Surge (kV)	(-) Surge (kV)
L1-PE	Complied	Complied
L2-PE	Complied	Complied

**Signal Lines**

Line to Earth – Common Mode

Mode of Application	Observations	
	(+) Surge (kV)	(-) Surge (kV)
RJ-45	Complied	Complied
Alarm	Complied	Complied

This report shall not be reproduced except in full, without the written approval of KES Co., Ltd.  
 The results shown in this test report refer only to the sample(s) tested unless otherwise stated.

- POE Mode

Line to Line – Differential Mode

Mode of Application	Observations	
	(+) Surge (kV)	(-) Surge (kV)
L – N	-	-
L – PE	-	-
N – PE	-	-

Line to Earth – Common Mode

Mode of Application	Observations	
	(+) Surge (kV)	(-) Surge (kV)
L1-PE	-	-
L2-PE	-	-

**Signal Lines**

Line to Earth – Common Mode

Mode of Application	Observations	
	(+) Surge (kV)	(-) Surge (kV)
RJ-45(POE)	Complied	Complied
Alarm	Complied	Complied

Note: "Blank" = Not performed

Observations:  
Complied – No degradation of function

**Test Results**

- PASS Required Performance Criteria  
 NOT PASS Required Performance Criteria

**Remarks**

PASS Required Performance Criteria.

### 3.5 Conducted Disturbance

**Reference Standard**

EN 61000-4-6:2014

**Test Date**

Jan, 16, 2017

**Test Location**

EMS-CS: Electro wave Shieldroom

**Test Equipment**

Used	Description	Model Number	Manufacturer	Serial Number	Cal. Due
<input checked="" type="checkbox"/>	Continuous Wave Generator	CWS 500N1	EM TEST	V0936105119	08, 08, 2017
<input checked="" type="checkbox"/>	6 dB Attenuator	ATT6	EM TEST	1208-34	08, 08, 2017
<input checked="" type="checkbox"/>	CDN	CDN-M2/M3N	EM TEST	0909-06	08, 08, 2017
<input checked="" type="checkbox"/>	EM Injection Clamp	EM 101	Liithi	35943	02, 04, 2017
<input checked="" type="checkbox"/>	EMS Test S/W	icd.control	EM TEST	5.3.7	-

**Test Conditions**Temperature: 24,1 °C  
Relative Humidity: 40,2 %  
Atmospheric Pressure: 100,2 kPa





**KES Co., Ltd.**

C-3701, Simin-daero 365-40,  
Dongan-gu, Anyang-si, Gyeonggi-do, 14057, Korea  
Tel: +82-31-425-6200 / Fax: +82-31-424-0450  
www.kes.co.kr

Test report No.:  
KES-E1-17T0042  
Page (34) of (79)

---

**Test Specifications**

- Frequency range:  150 kHz to 100 MHz  150 kHz to 80 MHz
- Voltage Level:  1 Vrms  3 Vrms  
 10 Vrms
- Modulation:  AM, 80 %, 1 kHz sine wave  
 PM, 1 Hz (0,5 s ON : 0,5 s OFF)
- Frequency step:  1 % step
- Dwell Time:  1 s  3 s
- Required Performance Criteria:  Complied

---

This report shall not be reproduced except in full, without the written approval of KES Co., Ltd.  
The results shown in this test report refer only to the sample(s) tested unless otherwise stated.



**Test Data**

- DC 12 V Mode

Input a.c. power ports

Coupling Location (Line Stressed)	Coupling Method	Observations
-	CDN ( <input type="checkbox"/> M2, <input type="checkbox"/> M3)	-

Input d.c. power ports

Coupling Location (Line Stressed)	Coupling Method	Observations
L1 - L2	CDN ( <input checked="" type="checkbox"/> M2, <input type="checkbox"/> M3)	Complied

Signal ports and telecommunication ports

Coupling Location (Line Stressed)	Coupling Method	Observations
RJ-45	Complied	Complied
Alarm	Complied	Complied

- PoE Mode

Input a.c. power ports

Coupling Location (Line Stressed)	Coupling Method	Observations
-	CDN ( <input type="checkbox"/> M2, <input type="checkbox"/> M3)	-

Input d.c. power ports

Coupling Location (Line Stressed)	Coupling Method	Observations
-	CDN ( <input type="checkbox"/> M2, <input type="checkbox"/> M3)	-

Signal ports and telecommunication ports

Coupling Location (Line Stressed)	Coupling Method	Observations
RJ-45	Complied	Complied
Alarm	Complied	Complied

Notes: CDN = Coupling Decoupling Network  
 "blank" = Not performed

Observations:  
 Complied – No degradation of function

**Test Results**

- PASS Required Performance Criteria
- NOT PASS Required Performance Criteria

**Remarks**

PASS Required Performance Criteria.



### 3.6 Voltage Dips and Short Interruptions

**Reference Standard**

EN 61000-4-11:2004

**Test Date**

N/A

**Test Location**

EMS-Voltage dip: Electro wave Shieldroom

**Test Equipment**

Used	Description	Model Number	Manufacturer	Serial Number	Cal. Due
<input type="checkbox"/>	Ultra Compact Simulator	UCS 500 N5	EM TEST	V0936105120	06, 27, 2017
<input type="checkbox"/>	Motor Variac	MV2616	EM TEST	V0936105123	06, 27, 2017
<input type="checkbox"/>	EMS Test S/W	iec.control	EM TEST AG	5.0.9.0	-

**Test Conditions**

Temperature: °C  
Relative Humidity: %  
Atmospheric Pressure: kPa

This report shall not be reproduced except in full, without the written approval of KES Co., Ltd.  
The results shown in this test report refer only to the sample(s) tested unless otherwise stated.



---

### Test Specifications & Observations/Remarks

(Test Voltage : 50 Hz)

<u>Test Level</u>	<u>Duration [in period/ms (50 Hz)]</u>	<u>Results</u>
<input type="checkbox"/> 20 % dip	<input type="checkbox"/> 250 /5000	<u>N/A</u>
<input type="checkbox"/> 30 % dip	<input type="checkbox"/> 25 /500	<u>N/A</u>
<input type="checkbox"/> 60 % dip	<input type="checkbox"/> 10 /200	<u>N/A</u>
<input type="checkbox"/> 100 % dip	<input type="checkbox"/> 250 /5000	<u>N/A</u>

- Voltage variations

<input type="checkbox"/> Unom + 10 %	<input type="checkbox"/> 253 V (ac)	<u>N/A</u>
<input type="checkbox"/> Unom - 15 %	<input type="checkbox"/> 195.5 V (ac)	<u>N/A</u>

Observations:

Complied – No degradation of function

#### Test Results

- PASS Required Performance Criteria
- NOT PASS Required Performance Criteria
- NOT APPLICABLE

#### Remarks

N/A Because the E.U.T power is 12 v (dc) power and PoE, limits are not specified.



---

## **APPENDIX A – TEST DATA**

### **Conducted Emissions at Mains Power Ports**

**[HOT]**

N/A

#### **◆ Calculation**

QuasiPeak[dBuV] / CAverage [dBuV] = Reading Value[dBuV] + Corr. [dB]

QuasiPeak / CAverage : The Final Value

Reading Value : Not shown in the table.

Corr. : Correction values (LISN FACTOR+ Cable Loss)

---

This report shall not be reproduced except in full, without the written approval of KES Co., Ltd.  
The results shown in this test report refer only to the sample(s) tested unless otherwise stated.



**KES Co., Ltd.**

C-3701, Simin-daero 365-40,  
Dongan-gu, Anyang-si, Gyeonggi-do, 14057, Korea  
Tel: +82-31-425-6200 / Fax: +82-31-424-0450  
www.kes.co.kr

Test report No.:  
KES-E1-17T0042  
Page (40) of (79)

---

**[NEUTRAL]**

N/A

◆ Calculation

QuasiPeak<sup>[dBuV]</sup> / CAverage<sup>[dBuV]</sup> = Reading Value<sup>[dBuV]</sup> + Corr. [dB]

QuasiPeak / CAverage : The Final Value

Reading Value : Not shown in the table.

Corr. : Correction values (LISN FACTOR+ Cable Loss)

---

This report shall not be reproduced except in full, without the written approval of KES Co., Ltd.  
The results shown in this test report refer only to the sample(s) tested unless otherwise stated.

## Conducted Emissions at Telecommunication Ports

- DC 12 V Mode

[10 Mbps]

### Common Information

Test Description:	Telecommunication Emission
Model No.:	XND-8030RP
Mode	DC 12 V _ 10 Mbps
Operator Name:	KES

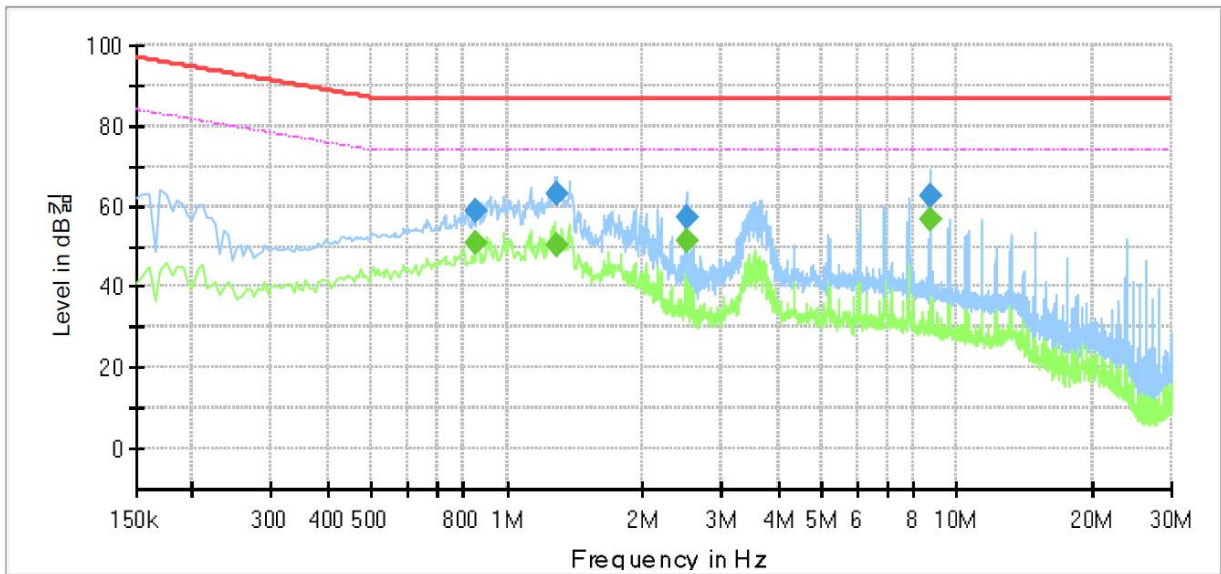

### Final Result

Frequency (MHz)	QuasiPeak (dBμV)	CAverage (dBμV)	Limit (dBμV)	Margin (dB)	Meas. Time (ms)	Bandwidth (kHz)	Line	Corr. (dB)
0.855000	---	50.75	74.00	23.25	1000.0	9.000	Single Line	20.5
0.855000	58.70	---	87.00	28.30	1000.0	9.000	Single Line	20.5
1.290000	---	50.28	74.00	23.72	1000.0	9.000	Single Line	20.2
1.290000	62.98	---	87.00	24.02	1000.0	9.000	Single Line	20.2
2.500000	---	51.15	74.00	22.85	1000.0	9.000	Single Line	19.9
2.500000	57.03	---	87.00	29.97	1000.0	9.000	Single Line	19.9
8.750000	---	56.52	74.00	17.48	1000.0	9.000	Single Line	19.9
8.750000	62.55	---	87.00	24.45	1000.0	9.000	Single Line	19.9

◆ Calculation

QuasiPeak[dBuV] / CAverage [dBuV] = Reading Value[dBuV] + Corr. [dB]

QuasiPeak / CAverage : The Final Value

Reading Value : Not shown in the table.

Corr. : Correction values (ISN FACTOR+ Cable Loss)

This report shall not be reproduced except in full, without the written approval of KES Co., Ltd.  
The results shown in this test report refer only to the sample(s) tested unless otherwise stated.



**[100 Mbps]**

**Common Information**

Test Description:	Telecommunication Emission
Model No.:	XND-8030RP
Mode	DC 12 V _ 100 Mbps
Operator Name:	KES

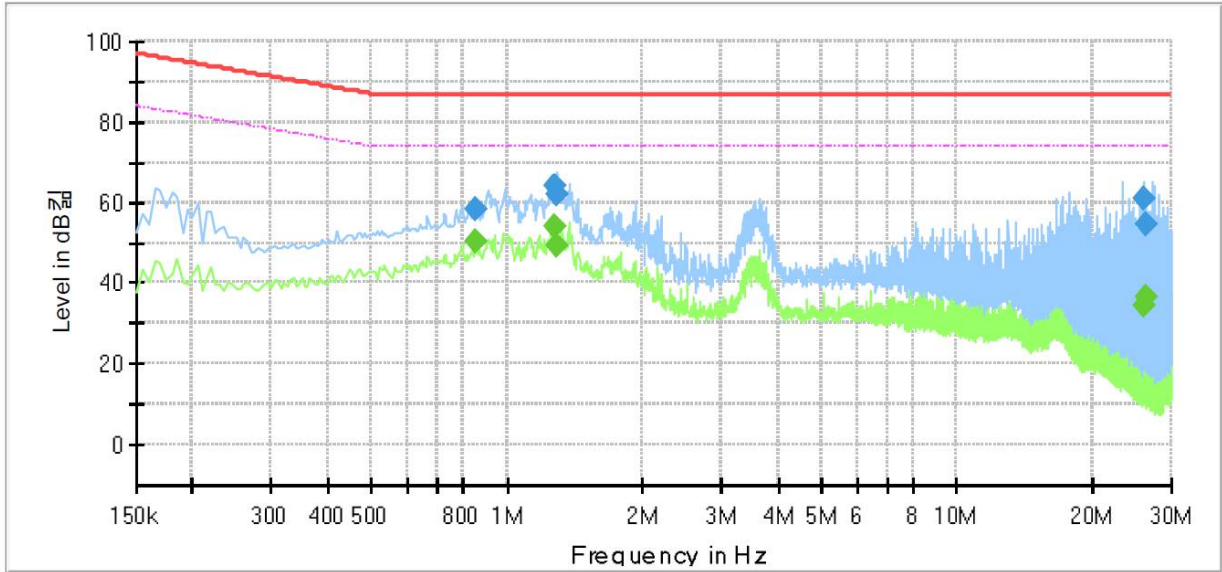

**Final Result**

Frequency (MHz)	QuasiPeak (dBμV)	CAverage (dBμV)	Limit (dBμV)	Margin (dB)	Meas. Time (ms)	Bandwidth (kHz)	Line	Corr. (dB)
0.855000	---	50.27	74.00	23.73	1000.0	9.000	Single Line	20.0
0.855000	58.17	---	87.00	28.83	1000.0	9.000	Single Line	20.0
1.275000	---	54.16	74.00	19.84	1000.0	9.000	Single Line	19.7
1.275000	63.97	---	87.00	23.03	1000.0	9.000	Single Line	19.7
1.295000	---	49.16	74.00	24.84	1000.0	9.000	Single Line	19.7
1.295000	61.73	---	87.00	25.27	1000.0	9.000	Single Line	19.7
25.955000	---	34.63	74.00	39.37	1000.0	9.000	Single Line	19.6
25.955000	60.63	---	87.00	26.37	1000.0	9.000	Single Line	19.6
26.385000	---	36.34	74.00	37.66	1000.0	9.000	Single Line	19.6
26.385000	54.48	---	87.00	32.52	1000.0	9.000	Single Line	19.6

◆ Calculation

QuasiPeak[dBuV] / CAverage [dBuV] = Reading Value[dBuV] + Corr. [dB]

QuasiPeak / CAverage : The Final Value

Reading Value : Not shown in the table.

Corr. : Correction values (ISN FACTOR+ Cable Loss)

This report shall not be reproduced except in full, without the written approval of KES Co., Ltd.  
 The results shown in this test report refer only to the sample(s) tested unless otherwise stated.

- PoE Mode

**[10 Mbps]**

## Common Information

Test Description:	Telecommunication Emission
Model No.:	XND-8030RP
Mode	POE_ 10 Mbps
Operator Name:	KES

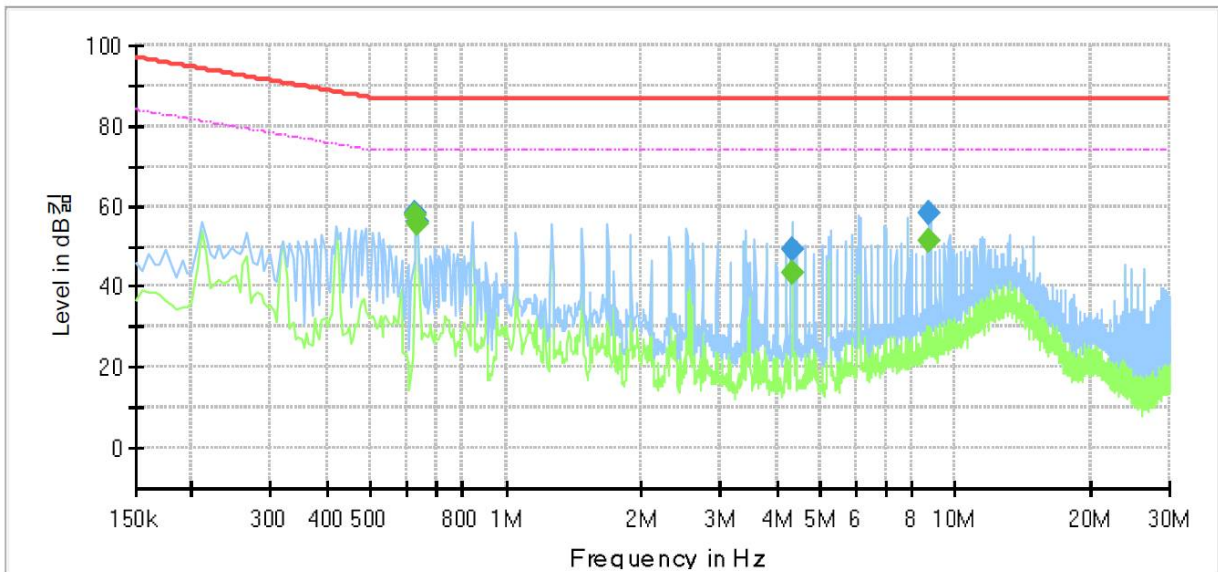

## Final Result

Frequency (MHz)	QuasiPeak (dBμV)	CAverage (dBμV)	Limit (dBμV)	Margin (dB)	Meas. Time (ms)	Bandwidth (kHz)	Line	Corr. (dB)
0.630000	---	57.72	74.00	16.28	1000.0	9.000	Single Line	20.7
0.630000	58.00	---	87.00	29.00	1000.0	9.000	Single Line	20.7
0.635000	---	55.32	74.00	18.68	1000.0	9.000	Single Line	20.7
0.635000	56.01	---	87.00	30.99	1000.0	9.000	Single Line	20.7
4.350000	---	43.22	74.00	30.78	1000.0	9.000	Single Line	19.8
4.350000	49.02	---	87.00	37.98	1000.0	9.000	Single Line	19.8
8.750000	---	51.37	74.00	22.63	1000.0	9.000	Single Line	19.9
8.750000	58.48	---	87.00	28.52	1000.0	9.000	Single Line	19.9

### ◆ Calculation

QuasiPeak[dBμV] / CAverage [dBμV] = Reading Value[dBμV] + Corr. [dB]

QuasiPeak / CAverage : The Final Value

Reading Value : Not shown in the table.

Corr. : Correction values (ISN FACTOR+ Cable Loss)

This report shall not be reproduced except in full, without the written approval of KES Co., Ltd.  
The results shown in this test report refer only to the sample(s) tested unless otherwise stated.

**[100 Mbps]**

**Common Information**

Test Description:	Telecommunication Emission
Model No.:	XND-8030RP
Mode	POE_ 100 Mbps
Operator Name:	KES

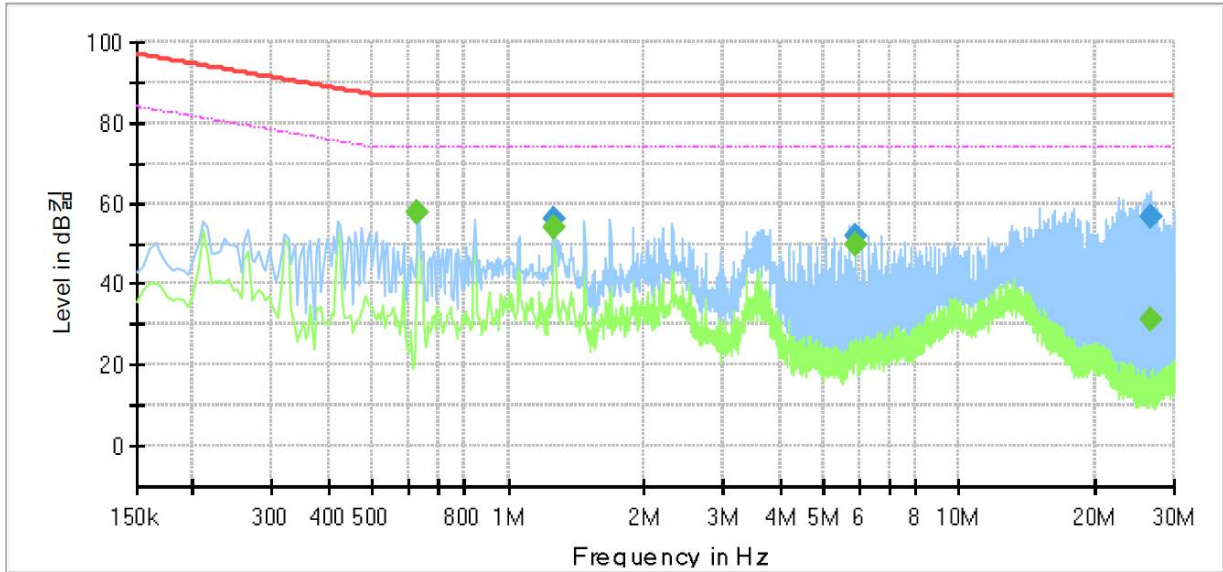

**Final Result**

Frequency (MHz)	QuasiPeak (dBμV)	CAverage (dBμV)	Limit (dBμV)	Margin (dB)	Meas. Time (ms)	Bandwidth (kHz)	Line	Corr. (dB)
0.630000	---	57.54	74.00	16.46	1000.0	9.000	Single Line	20.2
0.630000	57.90	---	87.00	29.10	1000.0	9.000	Single Line	20.2
1.265000	---	54.03	74.00	19.97	1000.0	9.000	Single Line	19.7
1.265000	55.92	---	87.00	31.08	1000.0	9.000	Single Line	19.7
5.895000	---	49.94	74.00	24.06	1000.0	9.000	Single Line	19.4
5.895000	51.68	---	87.00	35.32	1000.0	9.000	Single Line	19.4
26.610000	---	31.35	74.00	42.65	1000.0	9.000	Single Line	19.6
26.610000	56.65	---	87.00	30.35	1000.0	9.000	Single Line	19.6

◆ Calculation

QuasiPeak[dBuV] / CAverage [dBuV] = Reading Value[dBuV] + Corr. [dB]

QuasiPeak / CAverage : The Final Value

Reading Value : Not shown in the table.

Corr. : Correction values (ISN FACTOR+ Cable Loss)

**Radiated Electric Field Emissions(Below 1 GHz)**

This report shall not be reproduced except in full, without the written approval of KES Co., Ltd.  
The results shown in this test report refer only to the sample(s) tested unless otherwise stated.



- DC 12 V Mode

Frequency [MHz]	Amplitude [dB $\mu$ V]	ANT Polar. (H/V)	ANT. Height [m]	Correction Factor		Corrected Amplitude [dB $\mu$ V/m]	Applicable Limit [dB $\mu$ V/m]	Margin [dB]
				ANT. [dB/m]	Cable [dB]			
250.11	13.62	H	3.94	12.49	4.72	30.83	47.00	16.17
300.82	11.79	V	1.86	13.44	5.16	30.39	47.00	16.61
301.18	14.42	H	3.71	13.45	5.16	33.03	47.00	13.97
449.19	11.12	V	1.00	16.47	6.79	34.38	47.00	12.62
700.02	13.78	H	4.00	19.65	8.52	41.95	47.00	5.05
700.22	11.88	V	1.00	19.65	8.52	40.05	47.00	6.95

\* H : Horizontal, V : Vertical

◆ Calculation

Corrected Amplitude [dB $\mu$ V] = Amplitude[dBuV] + Correction Factor [dB]

Corrected Amplitude : The Final Value, Amplitude : Reading Value,

Correction Factor : ANT FACTOR + Cable loss

- PoE Mode

Frequency [MHz]	Amplitude [dB $\mu$ V]	ANT Polar. (H/V)	ANT. Height [m]	Correction Factor		Corrected Amplitude [dB $\mu$ V/m]	Applicable Limit [dB $\mu$ V/m]	Margin [dB]
				ANT. [dB/m]	Cable [dB]			
40.68	16.40	V	1.14	12.09	1.86	30.35	40.00	9.65
150.22	15.39	H	3.79	7.89	3.57	26.85	40.00	13.15
250.18	13.62	H	3.85	12.49	4.72	30.83	47.00	16.17
300.53	13.40	V	1.00	13.43	5.16	31.99	47.00	15.01
375.11	11.86	H	3.41	15.06	5.91	32.83	47.00	14.17
700.02	12.98	V	1.00	19.65	8.52	41.15	47.00	5.85

\* H : Horizontal, V : Vertical

◆ Calculation

Corrected Amplitude [dB $\mu$ V] = Amplitude[dBuV] + Correction Factor [dB]

Corrected Amplitude : The Final Value, Amplitude : Reading Value,

Correction Factor : ANT FACTOR + Cable loss

## Radiated Electric Field Emissions(Above 1 GHz)

- DC 12 V Mode

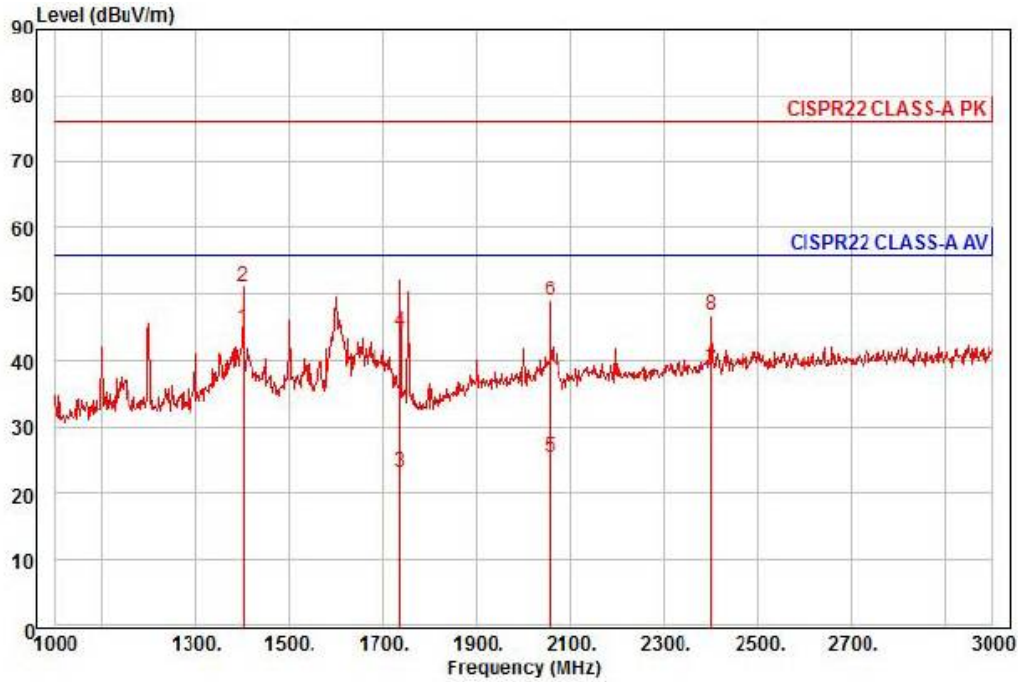

Site : chamber  
Condition: CISPR22 CLASS-A PK 3m HORN781(2015.05.07) horizontal  
: RBW:1000.000kHz VBW:1000.000kHz SWT:Auto  
Project :  
Model : XND-8030RP  
Mode : DC 12 V  
Memo :

	Read	Ant	Cable	Preamp	TPos	Limit	Over		
Freq	Level	Factor	Loss	Factor		Line	Limit	Pol/Phase	Remark
MHz	dBuV	dB/m	dB	dB	deg	dBuV/m	dB		
1 pp	1400.00	50.86	25.50	7.72	39.13	267	56.00	-11.05	horizontal Average
2 pk	1400.00	57.12	25.50	7.72	39.13	267	76.00	-24.79	horizontal Peak
3	1736.00	27.08	26.83	8.66	39.29	173	56.00	-32.72	horizontal Average
4	1736.00	48.10	26.83	8.66	39.29	173	76.00	-31.70	horizontal Peak
5	2056.00	27.46	28.02	9.47	39.41	173	56.00	-30.46	horizontal Average
6	2056.00	50.98	28.02	9.47	39.41	173	76.00	-26.94	horizontal Peak
7	2400.00	38.66	28.85	10.32	39.42	170	56.00	-17.58	horizontal Average
8	2400.00	47.04	28.85	10.32	39.42	170	76.00	-29.20	horizontal Peak

◆ Calculation

$$\text{Over Limit [dB]} = (\text{Read Level[dBuV]} + \text{Ant Factor[dB/m]} + \text{Cable Loss [dB]} - \text{Preamp Factor [dB]}) - \text{Limit Line[dBuV]}$$

Over Limit : Margin Value, Read Level : Reading Value, Ant Factor : Ant Factor,  
Cable Loss : Cable loss, Preamp Factor : Preamp Factor

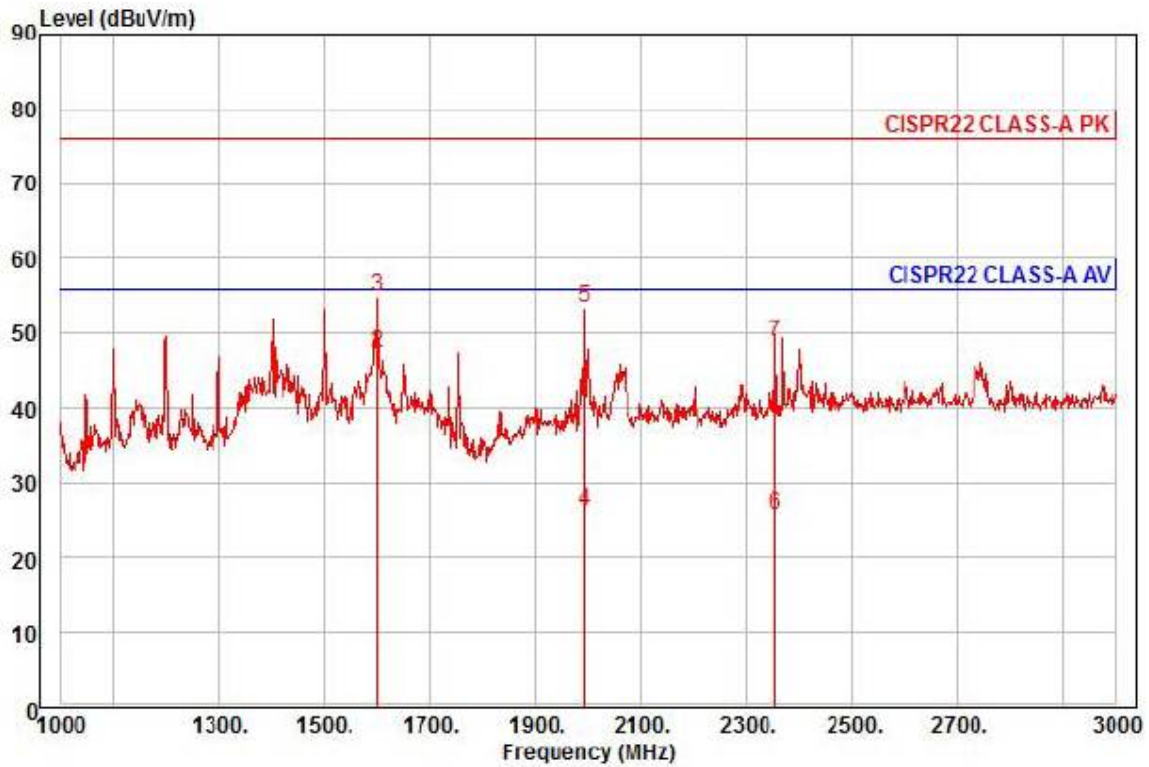

Site : chamber  
 Condition: CISPR22 CLASS-A PK 3m HORN781(2015.05.07) vertical  
 : RBW:1000.000kHz VBW:1000.000kHz SWT:Auto  
 Project :  
 Model : XND-8030RP  
 Mode : DC 12 V  
 Memo :

	Read Freq	Level	Ant Factor	Cable Loss	Preamp Factor	TPos	Limit Line	Over Limit	Pol/Phase	Remark
	MHz	dBuV	dB/m	dB	dB	deg	dBuV/m	dB		
1	1500.00	0.00	25.90	8.02	39.18	360	76.00	-81.26	vertical	Peak
2	1600.00	51.84	26.29	8.31	39.22	1	56.00	-8.78	vertical	Average
3	1600.00	59.65	26.29	8.31	39.22	1	76.00	-20.97	vertical	Peak
4	1994.00	28.48	27.86	9.32	39.41	188	56.00	-29.75	vertical	Average
5	1994.00	55.73	27.86	9.32	39.41	188	76.00	-22.50	vertical	Peak
6	2356.00	26.18	28.75	10.21	39.42	114	56.00	-30.28	vertical	Average
7	2356.00	49.38	28.75	10.21	39.42	114	76.00	-27.08	vertical	Peak

◆ Calculation

$$\text{Over Limit [dB]} = (\text{Read Level [dBuV]} + \text{Ant Factor [dB/m]} + \text{Cable Loss [dB]} - \text{Preamp Factor [dB]}) - \text{Limit Line [dBuV]}$$

Over Limit : Margin Value, Read Level : Reading Value, Ant Factor : Ant Factor,  
 Cable Loss : Cable loss, Preamp Factor : Preamp Factor

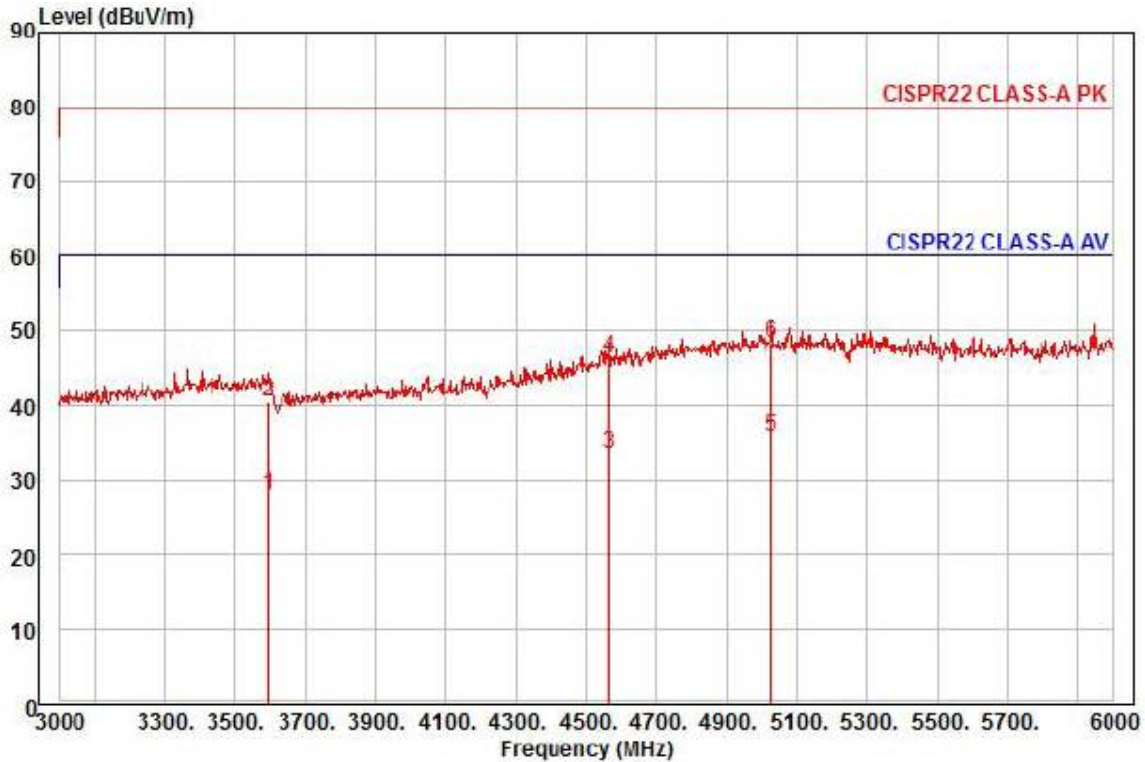

Site : chamber  
 Condition: CISPR22 CLASS-A PK 3m HORN781(2015.05.07) horizontal  
 : RBW:1000.000kHz VBW:1000.000kHz SWT:Auto  
 Project :  
 Model : XND-8030RP  
 Mode : DC 12 V  
 Memo :

	Read Freq	Read Level	Ant Factor	Cable Loss	Preamp Factor	TPos	Limit Line	Over Limit	Pol/Phase	Remark
	MHz	dBuV	dB/m	dB	dB	deg	dBuV/m	dB		
1	3594.00	24.78	31.33	12.79	40.85	94	60.00	-31.95	horizontal	Average
2	3594.00	37.21	31.33	12.79	40.85	94	80.00	-39.52	horizontal	Peak
3	4563.00	24.44	35.22	14.59	40.71	250	60.00	-26.46	horizontal	Average
4	4563.00	37.23	35.22	14.59	40.71	250	80.00	-33.67	horizontal	Peak
5 pp	5028.00	23.04	37.66	15.37	40.32	279	60.00	-24.25	horizontal	Average
6 pk	5028.00	35.52	37.66	15.37	40.32	279	80.00	-31.77	horizontal	Peak

◆ Calculation

$$\text{Over Limit [dB]} = (\text{Read Level[dBuV]} + \text{Ant Factor[dB/m]} + \text{Cable Loss [dB]} - \text{Preamp Factor [dB]}) - \text{Limit Line[dBuV]}$$

Over Limit : Margin Value, Read Level : Reading Value, Ant Factor : Ant Factor,  
 Cable Loss : Cable loss, Preamp Factor : Preamp Factor



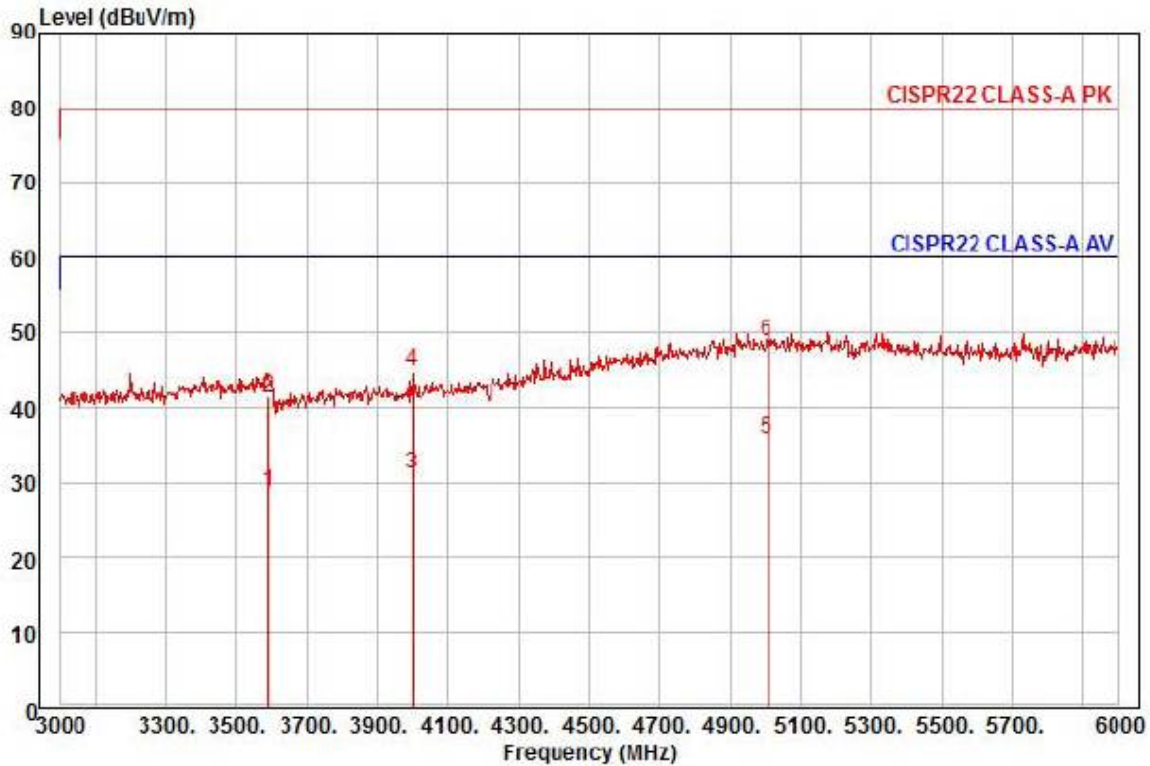

Site : chamber  
 Condition: CISPR22 CLASS-A PK 3m HORN781(2015.05.07) vertical  
 : RBW:1000.000kHz VBW:1000.000kHz SWT:Auto  
 Project :  
 Model : XND-8030RP  
 Mode : DC 12 V  
 Memo :

	Read Freq	Read Level	Ant Factor	Cable Loss	Preamp Factor	TPos	Limit Line	Over Limit	Pol/Phase	Remark
	MHz	dBuV	dB/m	dB	dB	deg	dBuV/m	dB		
1	3588.00	25.55	31.32	12.78	40.85	91	60.00	-31.20	vertical	Average
2	3588.00	38.10	31.32	12.78	40.85	91	80.00	-38.65	vertical	Peak
3	3999.00	26.40	32.01	13.56	40.70	214	60.00	-28.73	vertical	Average
4	3999.00	39.91	32.01	13.56	40.70	214	80.00	-35.22	vertical	Peak
5 pp	5004.00	23.13	37.71	15.32	40.28	200	60.00	-24.12	vertical	Average
6 pk	5004.00	36.06	37.71	15.32	40.28	200	80.00	-31.19	vertical	Peak

◆ Calculation

$$\text{Over Limit [dB]} = (\text{Read Level [dBuV]} + \text{Ant Factor [dB/m]} + \text{Cable Loss [dB]} - \text{Preamp Factor [dB]}) - \text{Limit Line [dBuV]}$$

Over Limit : Margin Value, Read Level : Reading Value, Ant Factor : Ant Factor,  
 Cable Loss : Cable loss, Preamp Factor : Preamp Factor



- PoE Mode

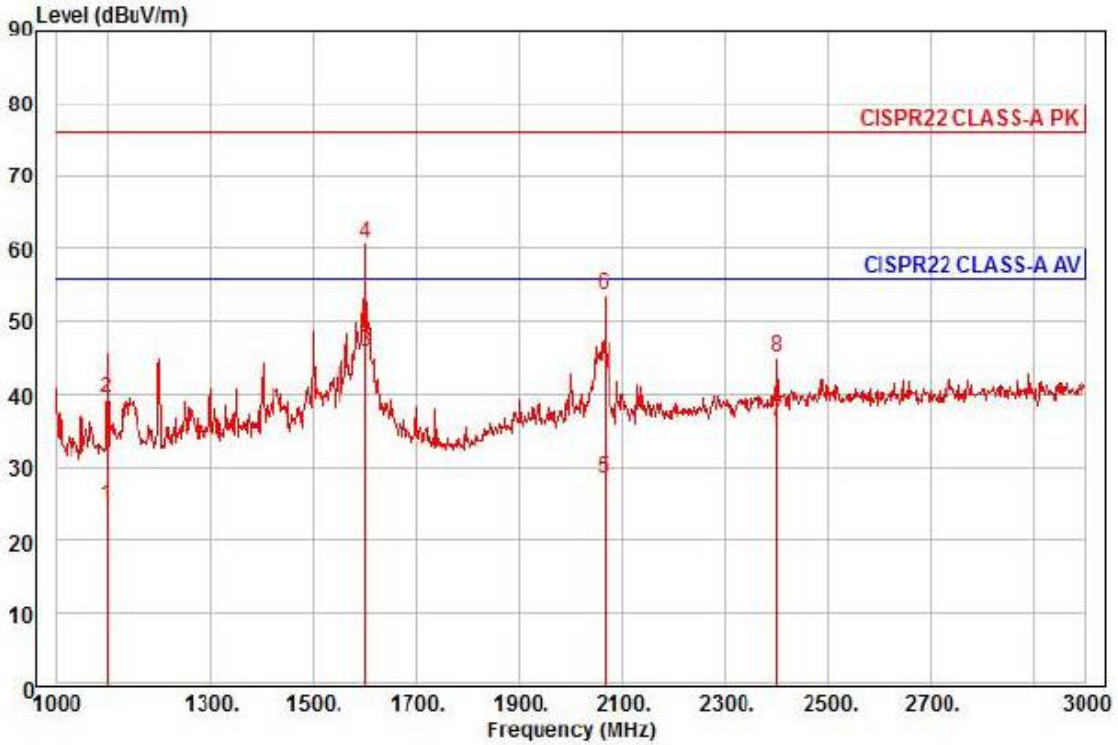

Site : chamber  
 Condition: CISPR22 CLASS-A PK 3m HORN781(2015.05.07) horizontal  
 : RBW:1000.000kHz VBW:1000.000kHz SWT:Auto  
 Project :  
 Model : XND-8030RP  
 Mode : POE  
 Memo :

	Read Freq	Read Level	Ant Factor	Cable Loss	Preamp Factor	TPos	Limit Line	Over Limit	Pol/Phase	Remark
	MHz	dBuV	dB/m	dB	dB	deg	dBuV/m	dB		
1	1098.00	33.47	24.30	6.80	39.85	125	56.00	-31.28	horizontal	Average
2	1098.00	48.21	24.30	6.80	39.85	125	76.00	-36.54	horizontal	Peak
3	1600.00	50.49	26.29	8.31	39.22	312	56.00	-10.13	horizontal	Average
4	1600.00	65.40	26.29	8.31	39.22	312	76.00	-15.22	horizontal	Peak
5	2066.00	30.44	28.04	9.49	39.41	330	56.00	-27.44	horizontal	Average
6	2066.00	55.51	28.04	9.49	39.41	330	76.00	-22.37	horizontal	Peak
7	2400.00	36.62	28.85	10.32	39.42	297	56.00	-19.62	horizontal	Average
8	2400.00	45.28	28.85	10.32	39.42	297	76.00	-30.96	horizontal	Peak

◆ Calculation

Over Limit [dB] = (Read Level[dBuV] + Ant Factor[dB/m] + Cable Loss [dB] - Preamp Factor [dB]) - Limit Line[dBuV]

Over Limit : Margin Value, Read Level : Reading Value, Ant Factor : Ant Factor,  
 Cable Loss : Cable loss, Preamp Factor : Preamp Factor

This report shall not be reproduced except in full, without the written approval of KES Co., Ltd.  
 The results shown in this test report refer only to the sample(s) tested unless otherwise stated.

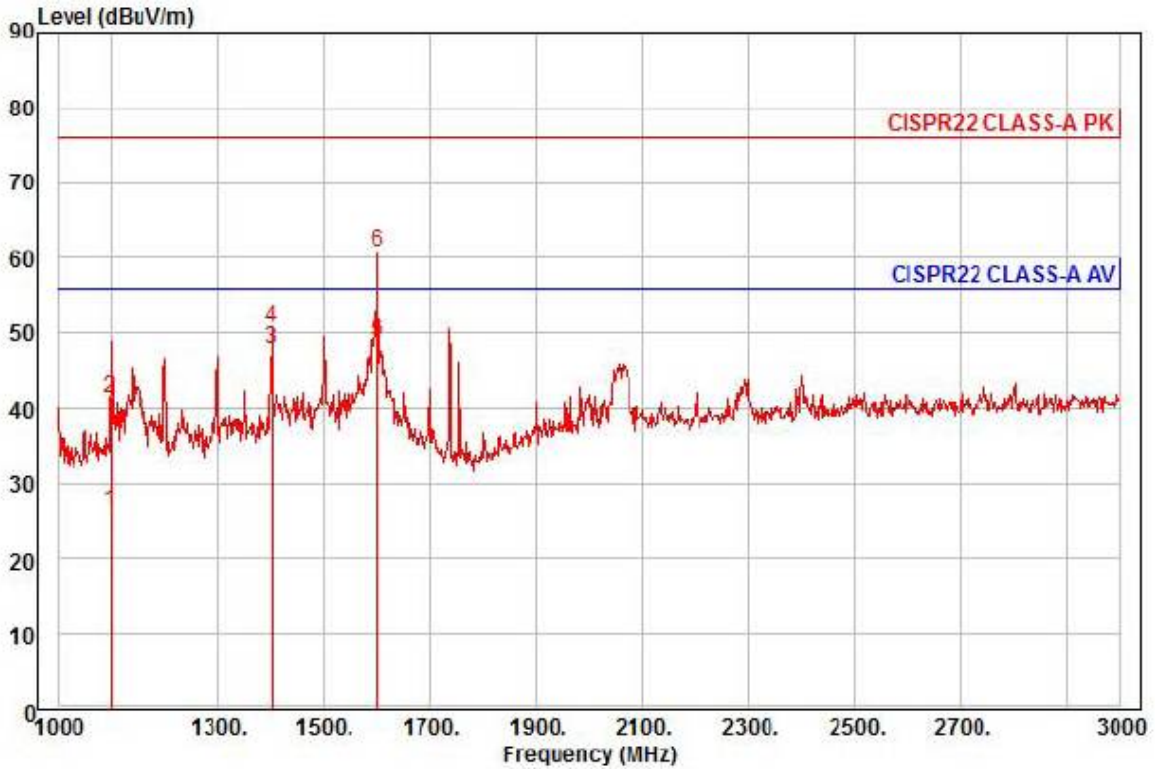

Site : chamber  
 Condition: CISPR22 CLASS-A PK 3m HORN781(2015.05.07) vertical  
 : RBW:1000.000kHz VBW:1000.000kHz SWT:Auto  
 Project :  
 Model : XND-8030RP  
 Mode : POE  
 Memo :

	Read Freq	Read Level	Ant Factor	Cable Loss	Preamp Factor	TPos	Limit Line	Over Limit	Pol/Phase	Remark
	MHz	dBuV	dB/m	dB	dB	deg	dBuV/m	dB		
1	1098.00	34.98	24.30	6.80	39.85	206	56.00	-29.77	vertical	Average
2	1098.00	50.20	24.30	6.80	39.85	206	76.00	-34.55	vertical	Peak
3	1400.00	53.69	25.50	7.72	39.13	238	56.00	-8.22	vertical	Average
4	1400.00	56.66	25.50	7.72	39.13	238	76.00	-25.25	vertical	Peak
5 pp	1600.00	53.53	26.29	8.31	39.22	27	56.00	-7.09	vertical	Average
6 pk	1600.00	65.48	26.29	8.31	39.22	27	76.00	-15.14	vertical	Peak

◆ Calculation

$$\text{Over Limit [dB]} = (\text{Read Level [dBuV]} + \text{Ant Factor [dB/m]} + \text{Cable Loss [dB]} - \text{Preamp Factor [dB]}) - \text{Limit Line [dBuV]}$$

Over Limit : Margin Value, Read Level : Reading Value, Ant Factor : Ant Factor,  
 Cable Loss : Cable loss, Preamp Factor : Preamp Factor

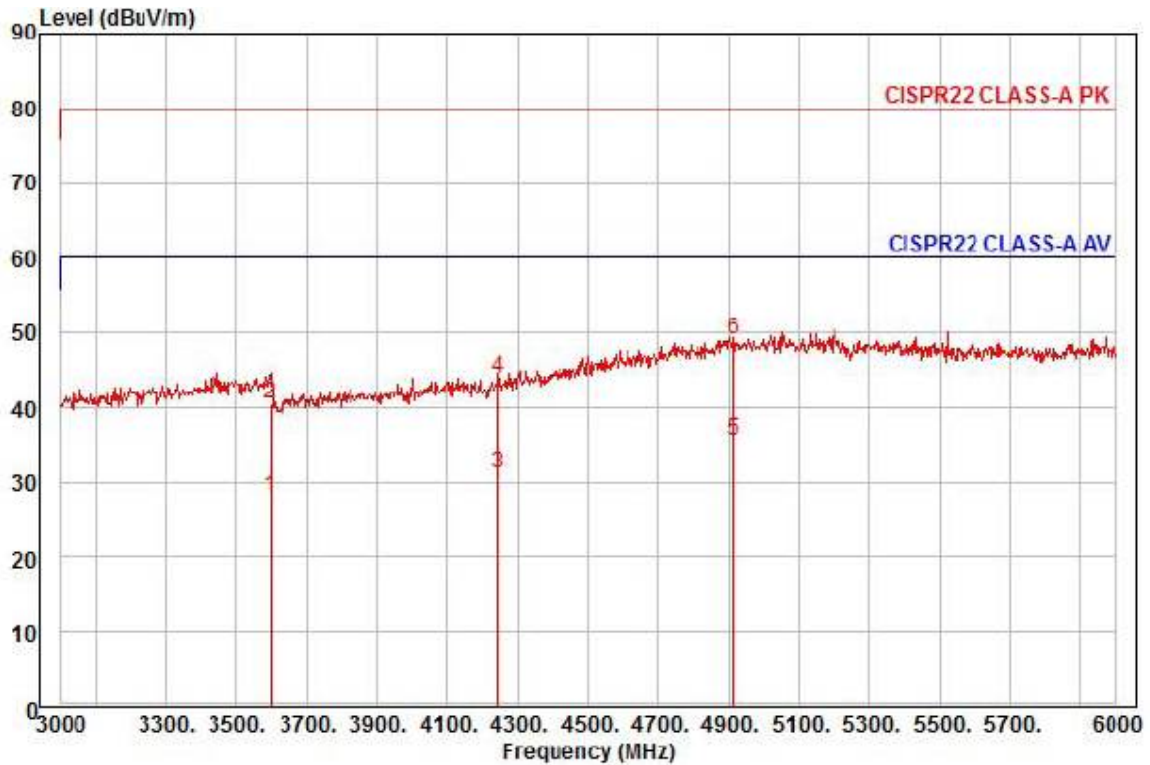

Site : chamber  
 Condition: CISPR22 CLASS-A PK 3m HORN781(2015.05.07) horizontal  
 : RBW:1000.000kHz VBW:1000.000kHz SWT:Auto  
 Project :  
 Model : XND-8030RP  
 Mode : POE  
 Memo :

	Read Freq	Level	Ant Factor	Cable Loss	Preamp Factor	TPos	Limit Line	Over Limit	Pol/Phase	Remark
	MHz	dBuV	dB/m	dB	dB	deg	dBuV/m	dB		
1	3597.00	24.66	31.33	12.80	40.85	55	60.00	-32.06	horizontal	Average
2	3597.00	37.28	31.33	12.80	40.85	55	80.00	-39.44	horizontal	Peak
3	4245.00	24.39	33.41	14.01	40.73	41	60.00	-28.92	horizontal	Average
4	4245.00	37.20	33.41	14.01	40.73	41	80.00	-36.11	horizontal	Peak
5 pp	4914.00	23.45	37.23	15.22	40.36	44	60.00	-24.46	horizontal	Average
6 pk	4914.00	36.96	37.23	15.22	40.36	44	80.00	-30.95	horizontal	Peak

◆ Calculation

$$\text{Over Limit [dB]} = (\text{Read Level [dBuV]} + \text{Ant Factor [dB/m]} + \text{Cable Loss [dB]} - \text{Preamp Factor [dB]}) - \text{Limit Line [dBuV]}$$

Over Limit : Margin Value, Read Level : Reading Value, Ant Factor : Ant Factor,  
 Cable Loss : Cable loss, Preamp Factor : Preamp Factor



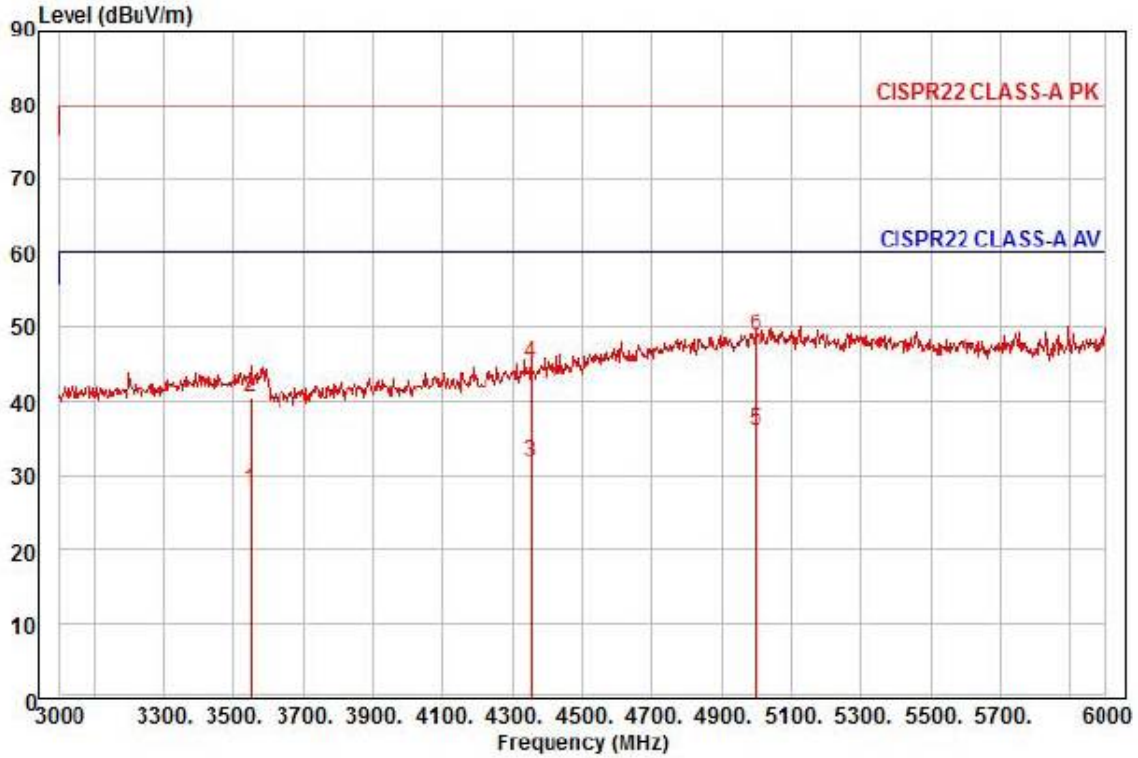

Site : chamber  
 Condition: CISPR22 CLASS-A PK 3m HORN781(2015.05.07) vertical  
 : RBW:1000.000kHz VBW:1000.000kHz SWT:Auto  
 Project :  
 Model : XND-8030RP  
 Mode : POE  
 Memo :

	Freq	Read Level	Ant Factor	Cable Loss	Preamp Factor	TPos	Limit Line	Over Limit	Pol/Phase	Remark
	MHz	dBuV	dB/m	dB	dB	deg	dBuV/m	dB		
1	3549.00	24.90	31.25	12.71	40.86	324	60.00	-32.00	vertical	Average
2	3549.00	37.33	31.25	12.71	40.86	324	80.00	-39.57	vertical	Peak
3	4353.00	24.49	34.03	14.19	40.75	136	60.00	-28.04	vertical	Average
4	4353.00	37.59	34.03	14.19	40.75	136	80.00	-34.94	vertical	Peak
5 pp	4998.00	23.20	37.71	15.31	40.27	197	60.00	-24.05	vertical	Average
6 pk	4998.00	35.96	37.71	15.31	40.27	197	80.00	-31.29	vertical	Peak

◆ Calculation

$$\text{Over Limit [dB]} = (\text{Read Level[dBuV]} + \text{Ant Factor[dB/m]} + \text{Cable Loss [dB]} - \text{Preamp Factor [dB]}) - \text{Limit Line[dBuV]}$$

Over Limit : Margin Value, Read Level : Reading Value, Ant Factor : Ant Factor,  
 Cable Loss : Cable loss, Preamp Factor : Preamp Factor

This report shall not be reproduced except in full, without the written approval of KES Co., Ltd.  
 The results shown in this test report refer only to the sample(s) tested unless otherwise stated.





**KES Co., Ltd.**

C-3701, Simin-daero 365-40,  
Dongan-gu, Anyang-si, Gyeonggi-do, 14057, Korea  
Tel: +82-31-425-6200 / Fax: +82-31-424-0450  
www.kes.co.kr

Test report No.:  
KES-E1-17T0042  
Page (55) of (79)

Test Data - Harmonics (continued)

**Maximum harmonic current results**

Hn	I <sub>eff</sub> [A]	% of Limit	Limit [A]	Result
N/A				

Harmonic currents less than 0.6% of the input current measured under the test conditions, or less than 5 mA, whichever is greater, are disregarded.

This report shall not be reproduced except in full, without the written approval of KES Co., Ltd.  
The results shown in this test report refer only to the sample(s) tested unless otherwise stated.



Test Data - Voltage Fluctuations

**Maximum Flicker results**

	<b>EUT values</b>	<b>Limit</b>	<b>Result</b>
Pst	N/A		
Plt			
dc [%]			
dmax [%]			
Tmax [s]			

This report shall not be reproduced except in full, without the written approval of KES Co., Ltd.  
The results shown in this test report refer only to the sample(s) tested unless otherwise stated.



**KES Co., Ltd.**

C-3701, Simin-daero 365-40,  
Dongan-gu, Anyang-si, Gyeonggi-do, 14057, Korea  
Tel: +82-31-425-6200 / Fax: +82-31-424-0450  
www.kes.co.kr

Test report No.:  
KES-E1-17T0042  
Page (57) of (79)

---

## **Test Setup Photos and Configuration**

### **Conducted Voltage Emissions**

N/A

---

This report shall not be reproduced except in full, without the written approval of KES Co., Ltd.  
The results shown in this test report refer only to the sample(s) tested unless otherwise stated.



---

## Conducted Telecommunication Emissions

- DC 12 V Mode



---

This report shall not be reproduced except in full, without the written approval of KES Co., Ltd.  
The results shown in this test report refer only to the sample(s) tested unless otherwise stated.

- PoE Mode

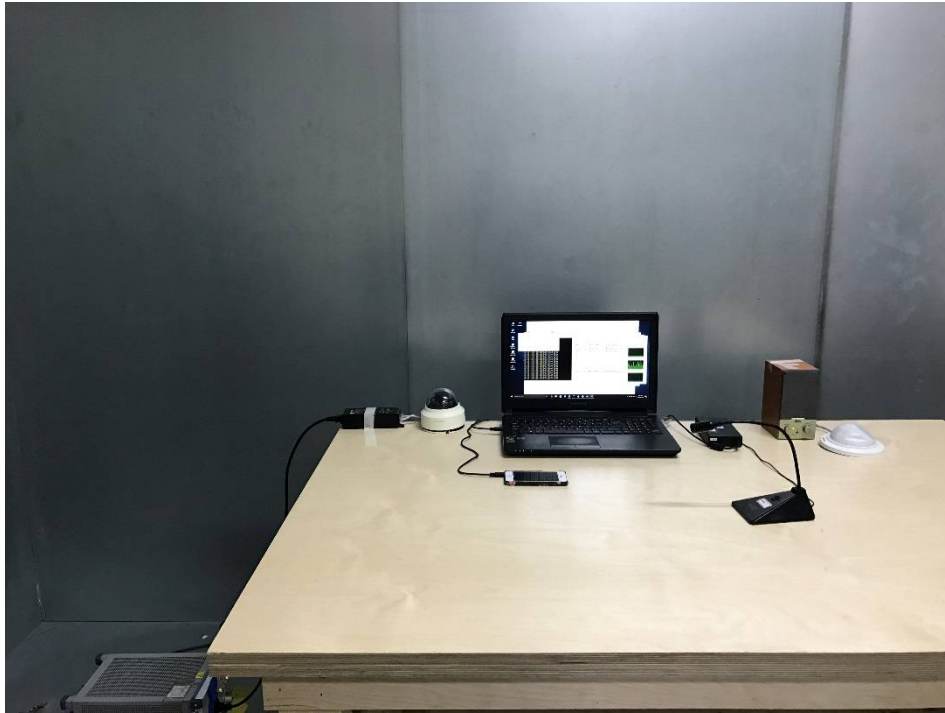

This report shall not be reproduced except in full, without the written approval of KES Co., Ltd.  
The results shown in this test report refer only to the sample(s) tested unless otherwise stated.

## Radiated Electric Field Emissions(Below 1 GHz)

- DC 12 V Mode



This report shall not be reproduced except in full, without the written approval of KES Co., Ltd.  
The results shown in this test report refer only to the sample(s) tested unless otherwise stated.



- PoE Mode



This report shall not be reproduced except in full, without the written approval of KES Co., Ltd.  
The results shown in this test report refer only to the sample(s) tested unless otherwise stated.

## Radiated Electric Field Emissions(Above 1 GHz)

- DC 12 V Mode

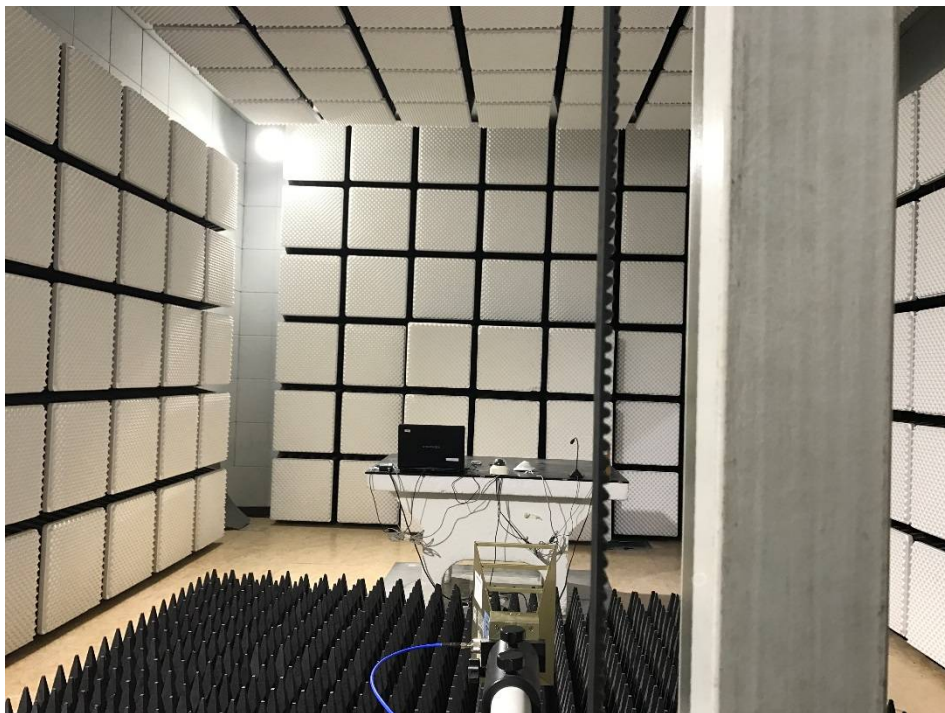
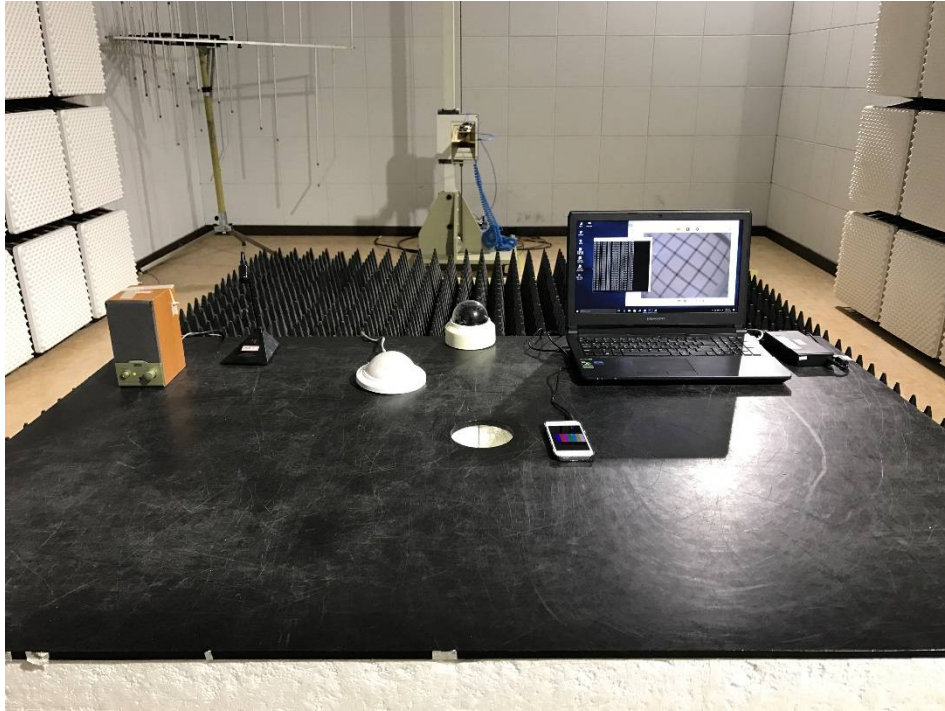

This report shall not be reproduced except in full, without the written approval of KES Co., Ltd.  
The results shown in this test report refer only to the sample(s) tested unless otherwise stated.



- PoE Mode

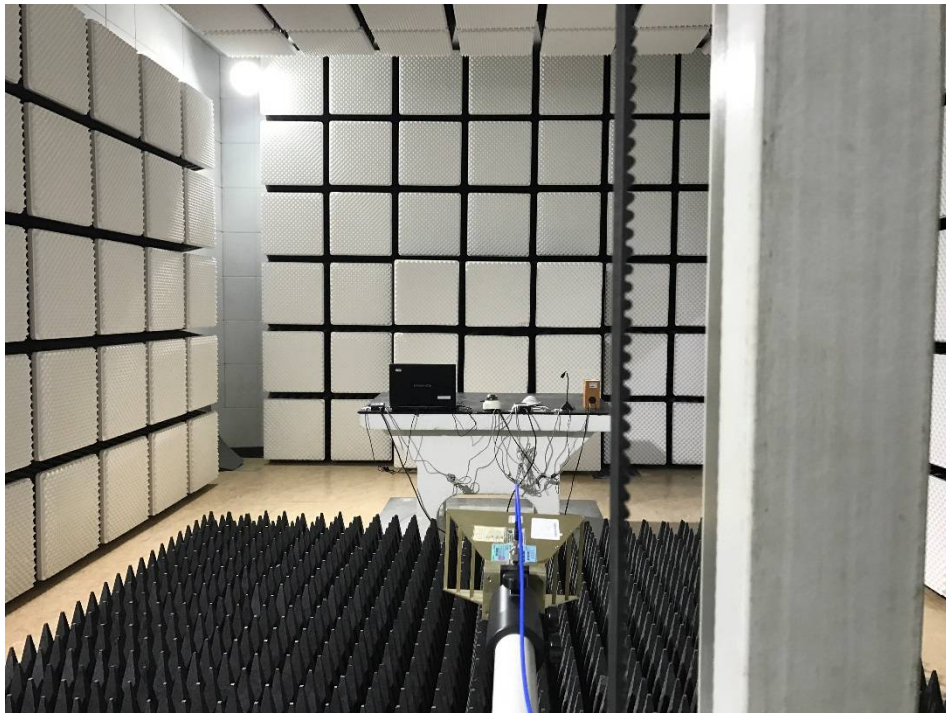
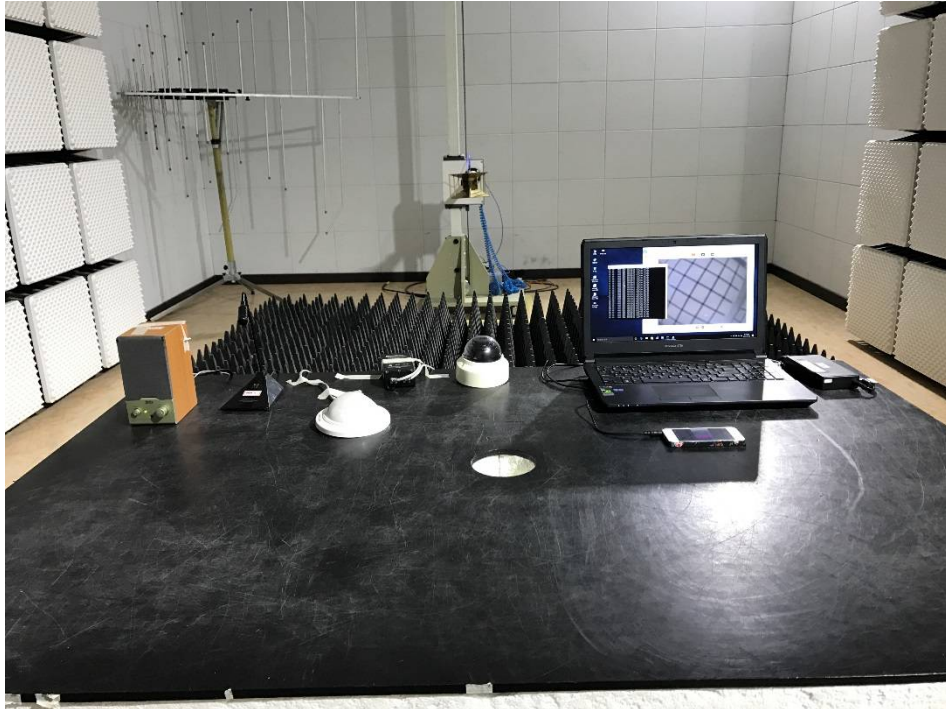

This report shall not be reproduced except in full, without the written approval of KES Co., Ltd.  
The results shown in this test report refer only to the sample(s) tested unless otherwise stated.



**KES Co., Ltd.**

C-3701, Simin-daero 365-40,  
Dongan-gu, Anyang-si, Gyeonggi-do, 14057, Korea  
Tel: +82-31-425-6200 / Fax: +82-31-424-0450  
www.kes.co.kr

Test report No.:  
KES-E1-17T0042  
Page (64) of (79)

---

## Harmonic Current Emissions and Voltage Fluctuations and Flicker

N/A

---

This report shall not be reproduced except in full, without the written approval of KES Co., Ltd.  
The results shown in this test report refer only to the sample(s) tested unless otherwise stated.

## Electrostatic Discharge

- DC 12 V Mode



- PoE Mode



This report shall not be reproduced except in full, without the written approval of KES Co., Ltd.  
The results shown in this test report refer only to the sample(s) tested unless otherwise stated.



## Radiated Electric Field Immunity

- DC 12 V Mode



- PoE Mode

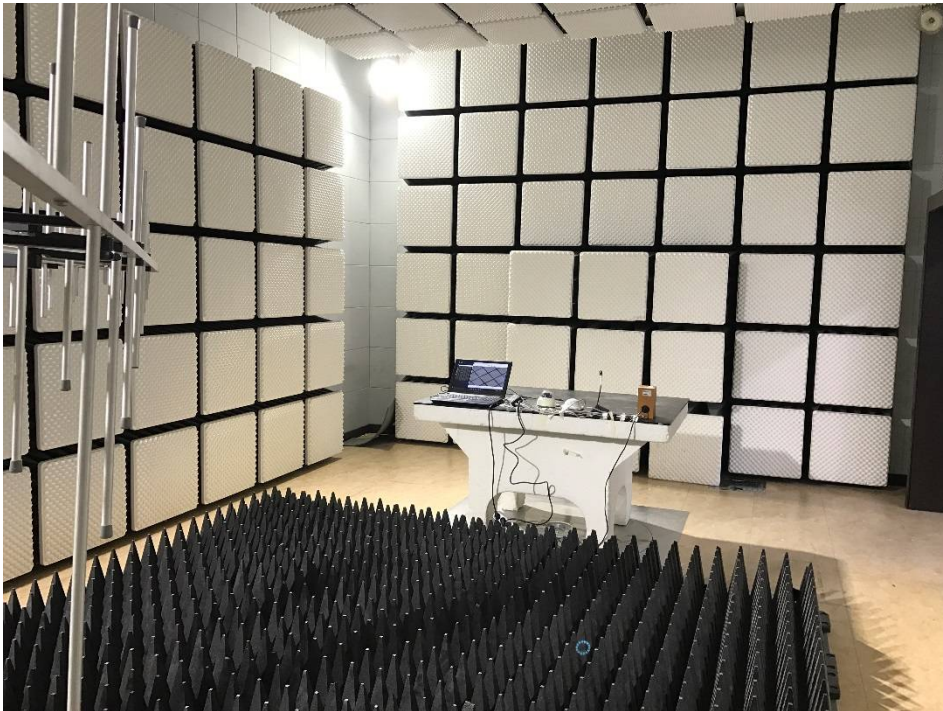

This report shall not be reproduced except in full, without the written approval of KES Co., Ltd.  
The results shown in this test report refer only to the sample(s) tested unless otherwise stated.

## Electrical Fast Transients/Bursts

- DC 12 V Mode

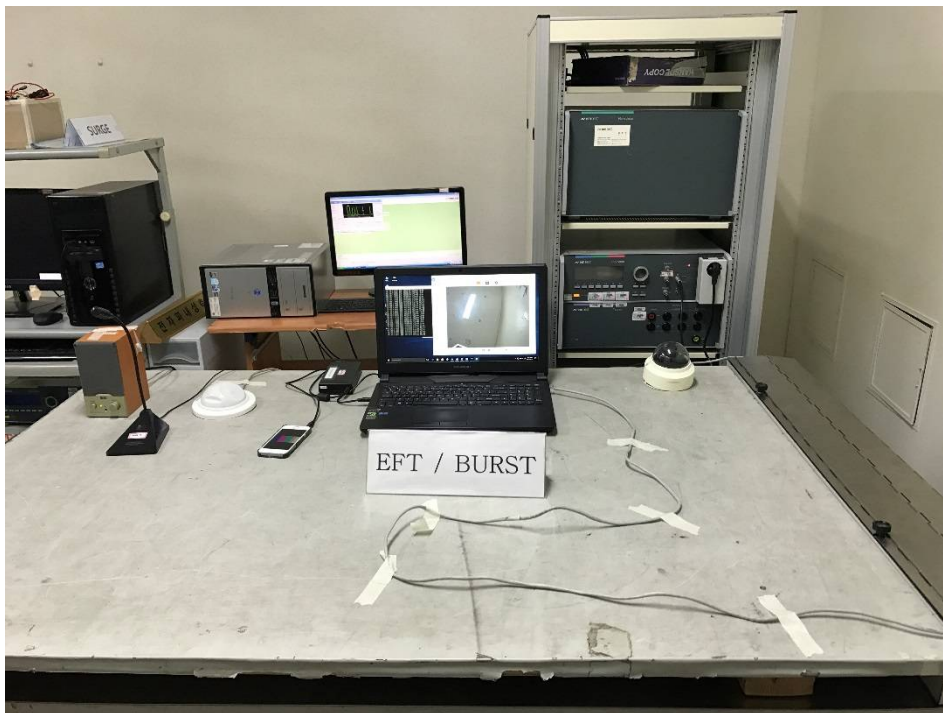

This report shall not be reproduced except in full, without the written approval of KES Co., Ltd.  
The results shown in this test report refer only to the sample(s) tested unless otherwise stated.



- PoE Mode

N/A



This report shall not be reproduced except in full, without the written approval of KES Co., Ltd.  
The results shown in this test report refer only to the sample(s) tested unless otherwise stated.

## Surge Transients

- DC 12 V Mode



- PoE Mode



This report shall not be reproduced except in full, without the written approval of KES Co., Ltd.  
The results shown in this test report refer only to the sample(s) tested unless otherwise stated.

## Conducted Disturbance

- DC 12 V Mode



This report shall not be reproduced except in full, without the written approval of KES Co., Ltd.  
The results shown in this test report refer only to the sample(s) tested unless otherwise stated.



- PoE Mode

N/A

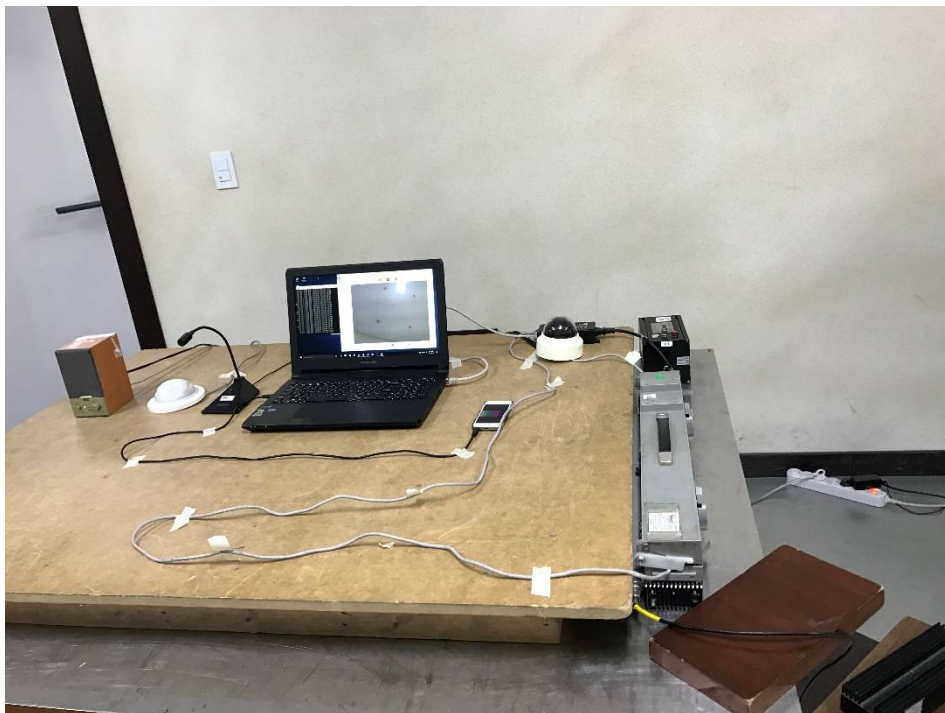

This report shall not be reproduced except in full, without the written approval of KES Co., Ltd.  
The results shown in this test report refer only to the sample(s) tested unless otherwise stated.



**KES Co., Ltd.**

C-3701, Simin-daero 365-40,  
Dongan-gu, Anyang-si, Gyeonggi-do, 14057, Korea  
Tel: +82-31-425-6200 / Fax: +82-31-424-0450  
www.kes.co.kr

Test report No.:  
KES-E1-17T0042  
Page (72) of (79)

---

## **Voltage Dips and Short Interruptions**

N/A

---

This report shall not be reproduced except in full, without the written approval of KES Co., Ltd.  
The results shown in this test report refer only to the sample(s) tested unless otherwise stated.



## EUT External Photographs

(Top)



(Bottom)



This report shall not be reproduced except in full, without the written approval of KES Co., Ltd.  
The results shown in this test report refer only to the sample(s) tested unless otherwise stated.

## EUT Internal Photographs

(Internal View)



This report shall not be reproduced except in full, without the written approval of KES Co., Ltd.  
The results shown in this test report refer only to the sample(s) tested unless otherwise stated.

### EUT Internal View – Board 1

(Top)



(Bottom)



This report shall not be reproduced except in full, without the written approval of KES Co., Ltd.  
The results shown in this test report refer only to the sample(s) tested unless otherwise stated.



## EUT Internal View – Board 2

(Top)



(Bottom)



This report shall not be reproduced except in full, without the written approval of KES Co., Ltd.  
The results shown in this test report refer only to the sample(s) tested unless otherwise stated.

### EUT Internal View – Board 3

(Top)



(Bottom)



This report shall not be reproduced except in full, without the written approval of KES Co., Ltd.  
The results shown in this test report refer only to the sample(s) tested unless otherwise stated.



## EUT Internal View – Board 4

(Top)



(Bottom)



This report shall not be reproduced except in full, without the written approval of KES Co., Ltd.  
The results shown in this test report refer only to the sample(s) tested unless otherwise stated.

## Label and Location



### **NETWORK CAMERA**

Model No : XND-8030RP

Manufacturer : Hanwha Techwin (Tianjin) Co.,Ltd.

Made in of Chin

